

# MODEL GW

## Valve Bagging Equipment

The Taylor GW Series Auger Packer is excellent for bagging a wide range of products: seeds, resins, plastics, sand, rubber granulars, fertilizers and abrasives. Practical design makes the GW Series transportable and adaptable to existing construction. To operate, place bag on spout and pull gate handle to start—fill shuts off automatically.

### Economical Valve Bagging

- Coarse powders
- Granular products
- 20 lb to 110 lb capacity
- Up to 3 bags per minute

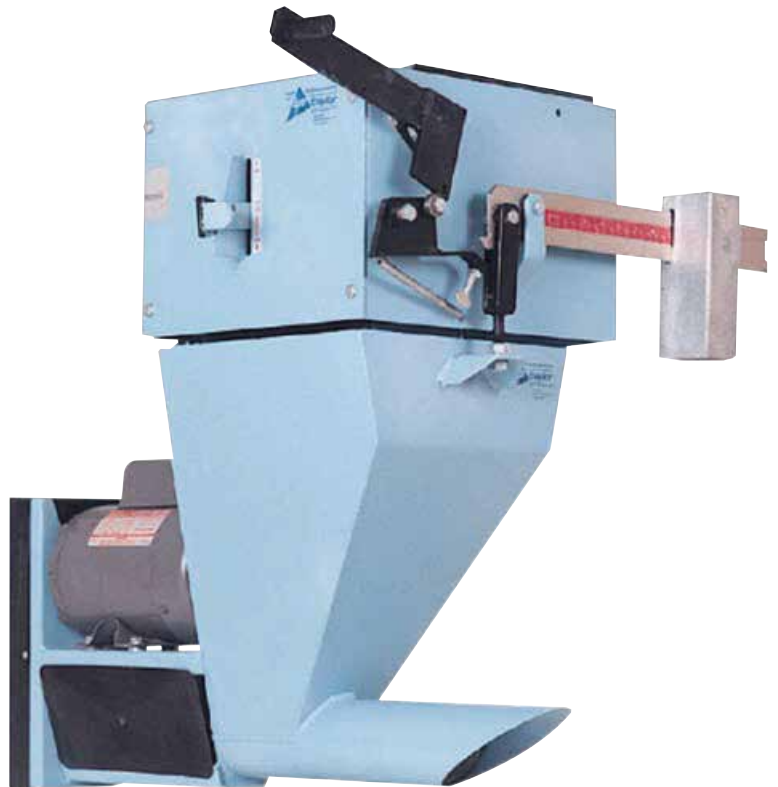
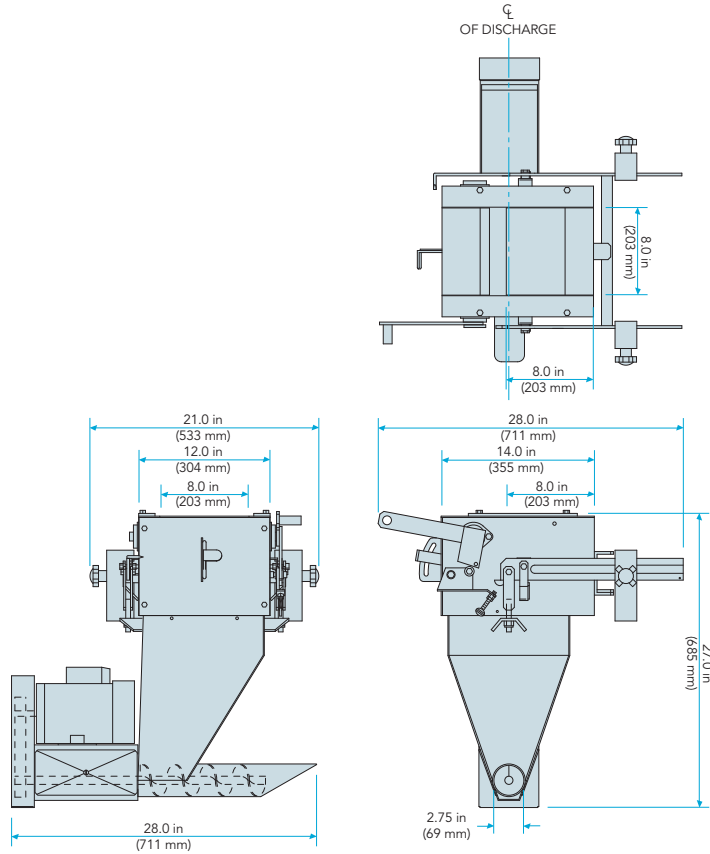



Diagram dimensions are for reference only

**GW**  
**MANUAL / BEAM**



<b>Dimensions</b>	27.0 in x 28.0 in x 28.0 in (685 mm x 711 mm x 711mm)
<b>Speed</b>	Up to 3 BPM
<b>Accuracy</b>	± 0.4 lbs
<b>Weight Range</b>	20 – 110 lbs
<b>Scale</b>	Beam
<b>Construction</b>	Carbon Steel Blasted and Painted
<b>Electrical Requirements</b>	115 V, single phase
<b>Popular Options</b>	Stainless Steel Construction

Note: Equipment selection can be varified in the Taylor Products test lab.



©2007 Magnum Systems, Inc. All rights reserved. Catalog number: MS.1037.0807