



# Electronic Impeller Packer

## Model IPV



Operation and Maintenance Manual



**MAGNUM**  
S Y S T E M S



2205 Jothi Avenue  
Parsons, Kansas 67357-8460

Toll Free: 888.882.9567  
Phone: 620.421.5550  
Fax: 620.421.5531

Web: [www.magnumsystems.com](http://www.magnumsystems.com)  
Email: [customerservice@magnumsystems.com](mailto:customerservice@magnumsystems.com)

**Machine Serial Number:** \_\_\_\_\_

**Sales Order Number:** \_\_\_\_\_

# Important Information

## Conventions

### Safety Alert Symbols

The  symbol indicates that important personal safety information follows. Carefully read this text for the warnings information it contains. The signal word next to each safety alert symbol is defined as:



#### **WARNING**

*Indicates a potentially hazardous situation that, if not avoided, could result in death or serious injury.*



#### **CAUTION**



Indicates a potentially hazardous situation that, if not avoided, may result in minor or moderate injury, or damage to the equipment. This single word may also be used to identify unsafe practices.



#### **LOCKOUT**

This symbol will be used anytime that a procedure requires an electrical lockout.

### Static Sensitive Symbols for Equipment Handling Instructions

The  and  symbols indicate important handling guidelines for proper handling of electronic equipment modules and sensitive components for the prevention of potential damage that could be caused by ESD (electrostatic discharge) during routine maintenance, handling and transportation.



#### **ESD NOTICE**

To protect against ESD damage to electronic equipment, follow the Standard ESD Prevention Procedures. Failure to use protective measures could result in permanent equipment damage, either immediate or latent, when handling modules.



#### **ESD NOTICE**

To protect against ESD damage to electronic equipment containing components, follow the Standard ESD Prevention Procedures. Failure to use recommended protective measures could result in permanent equipment damage, either immediate or latent, when handling components.

## Standard Electro-static Discharge (ESD) Prevention Procedures

The Model IPV utilizes many electronic components that are susceptible to damage from Electro Static Discharge. Anytime electronic components are serviced, the following precautions should be followed:

1. Wear a commercial grounding wrist strap.
2. Remove power from the machine.
3. Leave all static sensitive components in their protective packaging until it is time to install the component
4. Always hold static sensitive components by their metal mounting tabs, and/or by their edges

## Important/Notable Information

While all of the information in this manual is important, there are some pieces of information where special attention needs to be paid to avoid equipment damage, or specific information needs to be emphasized. This information will be handled as follows:

***Important:** Indicates an operating procedure, practice, or condition that, if not strictly followed, may cause equipment damage.*

***Note:** Indicates additional information or emphasizes a topic related to the subject being discussed.*

## Personal Safety Instructions

Only qualified personnel should work on or around this equipment. To ensure the highest degree of personal safety, all who use this equipment are required to become thoroughly familiar with all safety instructions contained in this document. Successful and safe operation of this equipment depends upon proper handling, operation, maintenance, and application of associated equipment. Refer to Appendix A of this manual for all safety instructions. Safety instructions are also provided where they apply within the body of this manual.



### **WARNING**

*No information in this manual supersedes or replaces your employer's operating rules. If there is a difference in instructions between this manual and the employer's operating rules, follow the most restrictive instruction.*

*Deliberate misuse or abuse of electronic components may cause personal injury or death.*

---

---

## **Warranty Information**

Seller warrants that the Products will operate substantially in conformance with Seller's published specifications, when subjected to normal, proper and intended usage by properly trained personnel, for a period of one (1) year from the date of shipment to Buyer (the "Warranty Period"). Seller agrees during the Warranty Period, provided it is promptly notified in writing upon the discovery of any defect and further provided that all costs of returning the defective Products to Seller are pre-paid by Buyer, to repair or replace, at Seller's option, defective Products so as to cause the same to operate in substantial conformance with said specifications. Replacement parts may be new or refurbished, at the election of Seller. All replaced parts shall become the property of Seller. Replacement Parts will be billed at list price, unless they are approved as warranty replacement item(s) by the service technician and the technical services manager.

**Lamps, fuses, bulbs and other expendable items are expressly excluded from the warranty. Seller's sole liability with respect to equipment, materials, parts or software furnished to Seller by third party suppliers shall be limited to the assignment by Seller to Buyer of any such third party supplier's warranty, to the extent the same is assignable. In no event shall Seller have any obligation to make repairs, replacements or corrections required, in whole or in part, as the result of (i) normal wear and tear, (ii) accident, disaster or event of force majeure, (iii) misuse, fault or negligence of or by Buyer, (iv) use of the Products in a manner for which they were not designed, (v) causes external to the Products such as, but not limited to, power failure or electrical power surges, (vi) improper storage of the Products or (vii) use of the Products in combination with equipment or software not supplied by Seller. If Seller determines that Products for which Buyer has requested warranty services are not covered by the warranty hereunder, Buyer shall pay or reimburse Seller for all costs of investigating and responding to such request at Seller's then prevailing time and materials rates. If Seller provides repair services or replacement parts that are not covered by the warranty, the Buyer shall pay Seller therefore at Seller's then prevailing time and materials rates. ANY INSTALLATION, MAINTENANCE, REPAIR, SERVICE, RELOCATION OR ALTERATION TO OR OF, OR OTHER TAMPERING WITH, THE PRODUCTS PERFORMED BY ANY PERSON OR ENTITY OTHER THAN SELLER WITHOUT SELLER'S PRIOR WRITTEN APPROVAL, OR ANY USE OF REPLACEMENT PARTS NOT SUPPLIED BY SELLER, SHALL IMMEDIATELY VOID AND CANCEL ALL WARRANTIES WITH RESPECT TO THE AFFECTED PRODUCTS.**

## **Field Service**

Magnum Systems can provide field service for start-up assistance, training, maintenance, and replacement/spare parts for new and existing equipment. Contact Magnum Systems at (888) 882-9567.

This Page Intentionally Left Blank

# Model IPV – Impeller Packer

## Table of Contents

Chapter	Page
<b>1 Product Description .....</b>	<b>1-1</b>
1.1 General Description .....	1-1
1.2 Introduction .....	1-1
1.3 Manual Scope .....	1-1
1.4 Electrical Requirements .....	1-1
1.5 Pneumatic Requirements .....	1-1
1.6 Dust Collection Requirements .....	1-1
1.7 Major Systems and Components .....	1-2
1.7.1 Base Frame .....	1-3
1.7.2 Hopper .....	1-3
1.7.3 Impeller Assembly .....	1-4
1.7.4 Packing Seal .....	1-4
1.7.5 Load Cell .....	1-5
1.7.6 Spout .....	1-5
1.7.6.1 Valve Bag Spout .....	1-5
1.7.6.2 Open Mouth Bag Spout .....	1-6
1.7.7 Weigh Mast .....	1-7
1.7.8 Flex Leaves .....	1-7
1.7.9 Dust Shroud .....	1-8
1.7.10 AC Motor .....	1-8
1.7.11 Drive Belts .....	1-9
1.7.12 MAC Valves .....	1-9
1.7.13 Bag Clamp .....	1-9
1.7.14 Bag Clamp Actuator Switch .....	1-10
1.7.15 Adjustable Pinch Valve .....	1-10
1.7.16 Filter/Regulator/Lubricator (FRL) Assembly .....	1-11
1.7.17 Bag Kicker .....	1-11
1.7.18 Bag Settlers .....	1-12
1.7.19 Bleed Air Control System .....	1-12
1.7.20 Machine Controls .....	1-13
1.7.20.1 Control Box With T4000 Control Panel .....	1-13
1.7.20.2 Control Box With T3000 Control Panel .....	1-15
<b>2 Receiving Equipment .....</b>	<b>2-1</b>
2.1 General Description .....	2-1
2.2 Uncrating the Equipment .....	2-1
<b>3 Setup/Installation .....</b>	<b>3-1</b>
3.1 General Description .....	3-1
3.2 Mechanical Setup .....	3-1
3.2.1 Supply Hopper .....	3-1
3.2.2 Dust Conduit for Supply Hopper .....	3-2

3.3	Electrical Connections .....	3-2
3.4	Pneumatic Connections .....	3-2
3.5	Making Network Connections .....	3-3
3.6	Security Settings .....	3-3
3.6.1	T4000 Security Settings .....	3-3
3.6.2	T3000 Security Settings .....	3-7
3.7	Dry Cycle .....	3-8
3.8	Calibration.....	3-9
3.8.1	Calibrating the T4000 Control Panel .....	3-9
3.8.2	Calibrating the Optional T3000 Control Panel .....	3-11
3.8.2.1	TRAD Calibration .....	3-12
<b>4</b>	<b>Operation .....</b>	<b>4-1</b>
4.1	General Description .....	4-1
4.2	General Fill Cycle Information .....	4-1
4.2.1	Basic Fill Process .....	4-1
4.3	Operational Controls .....	4-2
4.3.1	Operation Using Control Box With T4000 Control Panel .....	4-2
4.3.2	Operation Using Control Box With T3000 Control Panel .....	4-3
4.4	Starting the Unit .....	4-5
4.5	Initial Setup .....	4-5
4.5.1	Setting Up a Single Set Point Model IPV with T4000 Controls .....	4-5
4.5.2	Setting Up a Dual Set Point Model IPV with T4000 Controls .....	4-7
4.4.3	Setting Up a T3000 to Fill.....	4-9
4.4.3.1	Using the T3000 to Set Up A Product From Scratch .....	4-9
<b>5</b>	<b>Preventive Maintenance .....</b>	<b>5-1</b>
5.1	General Description .....	5-1
5.2	Daily Maintenance Procedures .....	5-1
5.2.1	Cleaning .....	5-1
5.2.2	Check All Fasteners .....	5-1
5.2.3	Drain Water From the FRL .....	5-2
5.3	Monthly Maintenance .....	5-2
<b>6</b>	<b>Troubleshooting.....</b>	<b>6-1</b>
6.1	General Description .....	6-1
6.2	The Troubleshooting Process.....	6-1
6.3	Trouble Symptoms .....	6-1
6.3.1	Scale is Not Accurate .....	6-1
6.3.2	Scale Does Not Return to Zero .....	6-2
6.3.3	The Weighments are Always Too Light .....	6-2
6.3.4	Load Cell Fails Frequently .....	6-2
6.3.5	Accuracy Problems While Doing a Wide Range of Weighments (i.e. 4 oz, 1 lb, and 5 lb).....	6-2
6.3.6	Weighments are Erratic.....	6-2
6.3.7	Machine Fails To Start After The START Switch Is Pressed.....	6-3
6.3.8	Fill speeds are too slow .....	6-3

6.4 System Alarms .....	6-4
6.4.1 T4000 Alarms.....	6-4
6.4.2 T3000 Alarms.....	6-5
6.4.2.1 Fill Alarms.....	6-5
6.4.2.2 Jog Alarms.....	6-5
6.4.2.3 Filler Discharge Alarms .....	6-5
<b>7 Repair and Adjustment .....</b>	<b>7-1</b>
7.1 General Description .....	7-1
7.2 System Adjustment Procedures .....	7-1
7.2.1 Air Pressure Adjustment .....	7-1
7.2.2 Impeller Shaft Seal Adjustment .....	7-1
7.2.3 Kicker Adjustment .....	7-2
7.2.3.1 T4000 Controls.....	7-2
7.2.3.2 T3000 Controls.....	7-2
7.2.4 Drive Belt Tension Adjustment.....	7-3
7.3 Component Replacement Procedures .....	7-4
7.3.1 Spout Replacement.....	7-4
7.3.1.1 Valve Bag Spout Replacement.....	7-4
7.3.1.1.1 Valve Bag Spout Removal.....	7-4
7.3.1.1.2 Valve Bag Spout Installation .....	7-4
7.3.1.2 Open Mouth Bag Spout Replacement .....	7-5
7.3.1.2.1 Open Mouth Bag Spout Removal.....	7-5
7.3.1.2.2 Open Mouth Bag Spout Installation .....	7-5
7.3.2 Inflatable Bladder Replacement (Open Mouth Bag Spout) .....	7-6
7.3.2.1 Inflatable Bladder Removal.....	7-6
7.3.2.2 Inflatable Bladder Installation .....	7-8
7.3.3 Load Cell Replacement .....	7-10
7.3.3.1 Load Cell Removal.....	7-10
7.3.3.2 Load Cell Installation .....	7-11
7.3.4 Drive Belt Replacement .....	7-11
7.3.4.1 Drive Belt Removal.....	7-11
7.3.4.2 Drive Belt Installation .....	7-12
7.3.5 AC Motor Replacement .....	7-12
7.3.5.1 AC Motor Removal.....	7-12
7.3.5.2 AC Motor Installation.....	7-13
7.3.6 Fill Hose Replacement .....	7-13
7.3.6.1 Fill Hose Removal.....	7-13
7.3.6.2 Fill Hose Installation .....	7-14
7.3.7 Flex Leaf Replacement.....	7-14
7.3.7.1 Flex Leaf Removal .....	7-14
7.3.8.2 Flex Leaf Installation.....	7-15
7.3.8 Impeller Replacement .....	7-15
7.3.8.1 Impeller Removal .....	7-15
7.3.8.2 Impeller Installation.....	7-15

7.3.9	Bag Clamp Cylinder Replacement.....	7-16
7.3.9.1	Bag Clamp Cylinder Removal.....	7-16
7.3.9.2	Bag Clamp Cylinder Installation.....	7-16
7.3.10	Bag Clamp Pad Replacement.....	7-17
7.3.10.1	Bag Clamp Pad Removal.....	7-17
7.3.10.2	Bag Clamp Pad Installation.....	7-17
7.3.11	Bag Clamp Actuator Switch Replacement.....	7-18
7.3.11.1	Bag Clamp Actuator Switch Removal.....	7-18
7.3.11.2	Bag Clamp Actuator Switch Installation.....	7-18
7.3.12	Adjustable Pinch Cylinder Replacement.....	7-19
7.3.12.1	Adjustable Pinch Valve Cylinder Removal.....	7-19
7.3.12.2	Adjustable Pinch Valve Cylinder Installation.....	7-19
7.3.13	Adjustable Pinch Valve Bar Replacement.....	7-20
7.3.13.1	Adjustable Pinch Valve Bar Removal.....	7-20
7.3.13.2	Adjustable Pinch Valve Bar Installation.....	7-20
7.3.14	Adjustable Pinch Valve Link Replacement.....	7-20
7.3.14.1	Adjustable Pinch Valve Link Removal.....	7-20
7.3.14.2	Adjustable Pinch Valve Link Installation.....	7-21
7.3.15	Air Supply Line Replacement.....	7-21
7.3.15.1	Air Supply Line Removal.....	7-21
7.3.15.2	Air Supply Line Installation.....	7-21
7.3.16	Air Fitting Replacement.....	7-22
7.3.16.1	Air Fitting Removal.....	7-22
7.3.16.2	Air Fitting Installation.....	7-22
7.3.17	Air Filter/Regulator/Lubricator (FRL) Replacement.....	7-23
7.3.17.1	FRL Assembly Removal.....	7-23
7.3.17.2	FRL Assembly Installation.....	7-23
7.3.18	MAC Valve Replacement.....	7-23
7.3.18.1	MAC Control Valve Removal.....	7-23
7.3.18.2	MAC Control Valve Installation.....	7-24
7.3.19	Impeller Shaft Replacement.....	7-24
7.3.19.1	Impeller Shaft Removal.....	7-24
7.3.19.2	Impeller Shaft Installation.....	7-24
7.3.20	Impeller Shaft Bearing Replacement.....	7-25
7.3.20.1	Impeller Shaft Bearing Removal.....	7-25
7.3.20.2	Impeller Shaft Bearing Installation.....	7-25
7.3.21	Impeller Shaft Seal Replacement.....	7-26
7.3.21.1	Impeller Shaft Seal Removal.....	7-26
7.3.21.2	Impeller Shaft Seal Installation.....	7-26
7.3.22	Bleed Air Control Filter Replacement.....	7-27
7.3.22.1	Bleed Air Control Filter Removal.....	7-27
7.3.22.2	Bleed Air Control Filter Installation.....	7-27

<b>Glossary.....</b>	<b>Glossary-1</b>
<b>Index.....</b>	<b>Index-1</b>
<b>Appendix A – Safety Precautions.....</b>	<b>A-1</b>
<b>Appendix B – Spare Parts.....</b>	<b>B-1</b>

**Appendix C – Mechanical Drawings.....C-1**  
**Appendix D – Electrical Drawings .....D-1**  
**Appendix E – T3000 Control Panel User Guide.....E-1**  
**Appendix F – Custom Features ..... F-1**

This Page Intentionally Left Blank

## List of Figures

<b>Figure</b>	<b>Page</b>
Figure 1-1. Base Frame.....	1-3
Figure 1-2. Hopper.....	1-3
Figure 1-3. Impeller Assembly .....	1-4
Figure 1-4. Load Cell.....	1-5
Figure 1-5. Valve Bag Spout .....	1-5
Figure 1-6. Open mouth bag spout .....	1-6
Figure 1-7. Blow Out Switch.....	1-6
Figure 1-8. Weigh Mast .....	1-7
Figure 1-9. Upper Flex Leaves .....	1-7
Figure 1-10. Lower Flex Leaves.....	1-7
Figure 1-11. Dust Shroud.....	1-8
Figure 1-12. AC Motor .....	1-8
Figure 1-13. Drive Belt System .....	1-9
Figure 1-14. MAC Valves.....	1-9
Figure 1-15. Bag Clamp.....	1-9
Figure 1-16. Bag Clamp Actuator Switch and Bale (Valve Bag Application).....	1-10
Figure 1-17. Adjustable Pinch Valve.....	1-10
Figure 1-18. Air Filter/Regulator/Lubricator (FRL).....	1-11
Figure 1-19. Kicker.....	1-11
Figure 1-20. Settler .....	1-12
Figure 1-21. Bleed Air Control System .....	1-12
Figure 1-22. T4000 Faceplate .....	1-13
Figure 1-23. Control Box With T4000 Control Panel .....	1-14
Figure 1-24. T3000 Faceplate Layout.....	1-15
Figure 1-25. Example of Model IPV Control Panel with T3000.....	1-16
Figure 2-1. Model IPV Fork Pockets (Arrows).....	2-2
Figure 2-2. Shipping Brackets Connecting the Weigh Mast to the Main Frame.....	2-2
Figure 3-1. Placing The Cursor In Front Of Security .....	3-3
Figure 3-2. Placing The Cursor In Front Of Set Password .....	3-4
Figure 3-3. Set Password Menu .....	3-4
Figure 3-4. Password Set To 123.....	3-5
Figure 3-5. Verify Password .....	3-5
Figure 3-6. SECUR Menu Item Shown Above Function button.....	3-6
Figure 3-7. Parameter Shown Locked .....	3-6
Figure 3-8. Placing the Cursor In Front Of Calibration.....	3-9
Figure 3-9. Placing The Cursor In Front Of Trad Cal .....	3-9
Figure 3-10. Placing The Cursor In Front Of Zero Value .....	3-10
Figure 3-11. Span Value Displayed .....	3-10
Figure 3-12. Calibration Line .....	3-12
Figure 3-13. Selecting TRAD Calibration .....	3-12
Figure 3-14. Checking Zero Value .....	3-12

Figure 3-15. Setting Span Value.....	3-13
Figure 4-1. Bulk Rate vs. Dribble Rate.....	4-1
Figure 1-2. T4000 Faceplate.....	4-2
Figure 4-3. Control Box With T4000 Control Panel.....	4-3
Figure 4-4. T3000 Faceplate Layout.....	4-3
Figure 4-5. T3000 Control Panel.....	4-4
Figure 4-6. ON/OFF Switch.....	4-5
Figure 4-7. Initial Setup – Single Set Point.....	4-6
Figure 4-8. SP1 Adjustment Screen.....	4-6
Figure 4-9. Model IPV ON/OFF Switch.....	4-7
Figure 4-10. Setting the Dribble Weight (SP2).....	4-7
Figure 4-11. SP1 Adjustment Screen.....	4-8
Figure 4-12. Setting the Target Weight (SP2).....	4-8
Figure 4-13. SP2 Adjustment Screen.....	4-8
Figure 5-1. Filter/Regulator/Lubricator Assembly – Drain Valve.....	5-2
Figure 7-1. Air Pressure Adjustment.....	7-1
Figure 7-2. Kicker Timer Delay Adjustment Knob.....	7-2
Figure 7-3. Belt Tension Adjustment Mechanism.....	7-3
Figure 7-4. Spout Replacement.....	7-4
Figure 7-5. Open Mouth Bag Spout Mounting Bracket.....	7-5
Figure 7-6. Section View of Open Mouth Bag Spout and Inflatable Bladder.....	7-6
Figure 7-7. Inflatable Bladder Compression Ring.....	7-7
Figure 7-8. Creating the Flap.....	7-8
Figure 7-9. Pulling the Bladder Up, and Creating the Upper Flap.....	7-9
Figure 7-10. Load Cell Mounting.....	7-10
Figure 7-11. Drive Belts.....	7-11
Figure 7-12. Drive Motor Mounting.....	7-12
Figure 7-13. Fill Assembly, Exploded View.....	7-13
Figure 7-14. Flex Leaves – Exploded View.....	7-14
Figure 7-15. Impeller, Exploded View.....	7-15
Figure 7-16. Bag Clamp Cylinder.....	7-16
Figure 7-17. Bag Clamp Pad.....	7-17
Figure 7-18. Adjustable Pinch Cylinder Mounting.....	7-19
Figure 7-19. Air Supply Fitting.....	7-22
Figure 7-20. MAC Valve – Solenoid Removed.....	7-23
Figure 7-21. Impeller Shaft Bearings.....	7-25
Figure 7-22. Impeller Shaft Seal, Exploded View.....	7-26
Figure 7-23. Bleed Air Control Wafer Filter.....	7-27

## List of Tables

<b>Table</b>	<b>Page</b>
Table B-1. Model IPV Spare Parts List .....	B-1
Table C-1. Model IPV Mechanical Drawings .....	C-1
Table D-1. Model IPV Electrical Drawings .....	D-1

This Page Intentionally Left Blank

# Chapter 1

## Product Description

### 1.1 General Description

This chapter will provide a high-level overview of the Model IPV. The Model IPV is an impeller packer. This chapter will cover the major components, along with the electrical and pneumatic requirements.

### 1.2 Introduction

The Model IPV offers one of the most advanced weighing and control packages available. Using a single load cell, the Model IPV is a very economical and accurate scale. Tests show that it will maintain consistent accuracy ( $\pm 0.2$  pounds) on free flowing materials, regardless of target weight setting. It is capable of accurately packaging fine powdered products into 20 to 125 pound bags.

The electrical design has the electronic components doing double duty, which minimizes the size of the control cabinet.

### 1.3 Manual Scope

This manual will provide information on description, receiving, setup/installation, operation, preventive maintenance, troubleshooting, and repair/adjustment of the Model IPV.

The appendices will include safety instructions, spare parts information, and engineering drawings.

### 1.4 Electrical Requirements

The Model IPV requires two different electrical sources. The electronic controls operate on 115 VAC, 60 Hertz, single-phase power. The standard impeller motor requires a 230 VAC, 3-phase, 60 Hz unit power source. An optional impeller motor is available that requires 460VAC, 3-phase, 60 Hz power. The control panel and the impeller motor each have their own power cord and plug.

### 1.5 Pneumatic Requirements

The Model IPV requires an air supply line that is capable of consistently delivering 90 PSI (.62 MPa) at 5 CFM (142 liters) for proper operation.

### 1.6 Dust Collection Requirements

If the bagging process will generate dust, the conduit fittings must be dust-tight and satisfy any hazard requirements for the product and site.

Use the 4-inch O.D. Dust Pickup Spout on the back of the dust shroud to connect the Model IPV to a dust collection system. The dust collection duct should have a blast gate to control the flow of air at the spout. Excessive airflow could create vacuum forces at the spout and affect weights.

## 1.7 Major Systems and Components

The main body of the unit consists of a flanged inlet chute on which the electric weigh meter box (control panel) is mounted. The inlet chute directs the material from a storage bin above to the bag-filling/weighing spout below. The inlet chute includes two pneumatically operated gates. The cutoff gate starts and stops the flow of material. The dribble gate controls the rate of flow of the material through the chute in two stages. The dribble gate is retracted during the initial stage of filling a bag to provide maximum flow of material into the bag. Then, the dribble gate is automatically extended during the final stage of filling. The extension of the dribble gate restricts the opening through which the material is flowing, and the resulting reduced flow allows a more accurate cutoff at the target weight. Also, the dribble gate can be manually adjusted to control the inlet throat size during the initial filling stage. This allows control of the fill rate to accommodate products of various densities. A 4-inch diameter stub is provided on the back of the body for connecting dust control piping.

The standard Model IPV is composed of the following components:

- Base frame
- Hopper
- Impeller and impeller box
- Packing seal
- Impeller shaft seals
- Load cell
- Spout
- Weigh mast
- Flex leaves
- Dust shroud
- 7 ½ horsepower AC motor
- Drive belts
- Bag clamp
- Bag clamp actuator switch
- Adjustable pinch valves
- Filter/Regulator/Lubricator (FRL) assembly
- Kicker/settler
- Control boxes

### 1.7.1 Base Frame

The base frame is the backbone of the Model IPV. It provides a support structure for the all of the other components that make up the Model IPV.

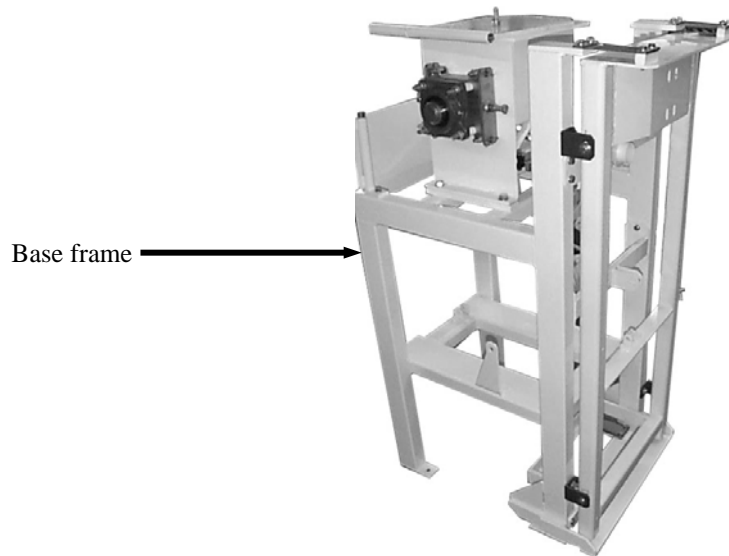

**Figure 1-1.** Base Frame

### 1.7.2 Hopper

The hopper is mounted at the top of the Model IPV, directly above the impeller box. It is used as a reservoir for the material that is to be packaged using the Model IPV. The hopper is loaded from the top using a hopper feeder. The material flows out of the bottom of the hopper into the impeller box.

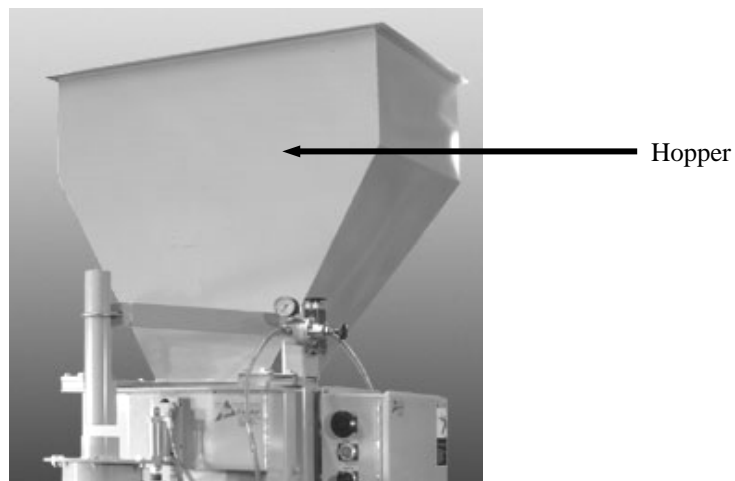

**Figure 1-2.** Hopper

## General Description

### 1.7.3 Impeller Assembly

Located directly below the hopper, is the impeller assembly. The assembly is composed of the impeller box, the impeller, the impeller shaft and bearings.

As its name implies, the impeller box houses the vertical impeller.

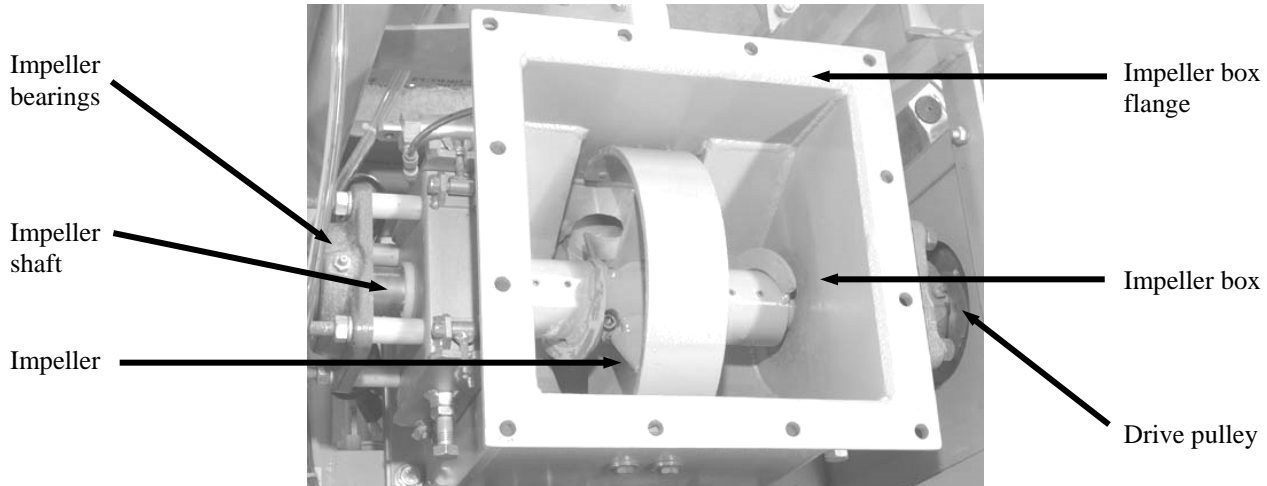

**Figure 1-3.** Impeller Assembly

The impeller is mounted in center of the impeller box. The impeller is equipped with four impeller blades that are used to force the material through the spout into the package. The impeller rides on a shaft that is supported by a bearing assembly on each end. The shaft also has a pulley mounted on the right side that is driven by the AC motor, via two drive belts.

### 1.7.4 Packing Seal

In between the supply hopper and the impeller box is a packing seal. This seal is a single piece of adhesive backed foam. The purpose of the seal is to prevent dust from leaking out between the supply hopper and the impeller box. This seal is hand cut from a sheet of the material.

## 1.7.5 Load Cell

The load cell is used to sense the weight of the material in the package. As material is loaded into the package, the load cell increases its voltage output to the weigh meter.



### CAUTION

A sudden jerk or shock, such as being struck by a tool or hitting the spout, etc., can cause load cell damage. The load cell is NOT covered by warranty.

**Important:** Never lift or move a machine by the weighing mechanism. Only lift the Model IPV by the base frame. Always use the shipping brackets when moving or shipping machines.

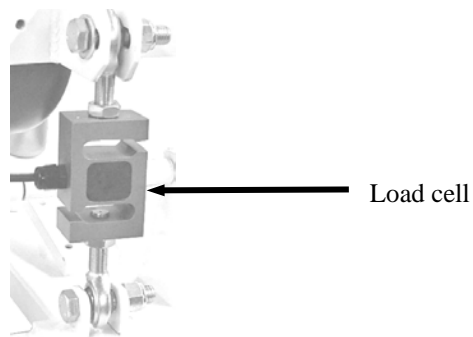

Figure 1-4. Load Cell

## 1.7.6 Spout

The spout assembly is used for transferring the material from the impeller box into the package. There are two types of spouts:

- Valve bag spout
- Open mouth bag spout

### 1.7.6.1 Valve Bag Spout

The standard Model IPV is equipped with a valve bag spout. This type of spout is used to fill valve bags. The IPV of the spout is inserted into the bag.

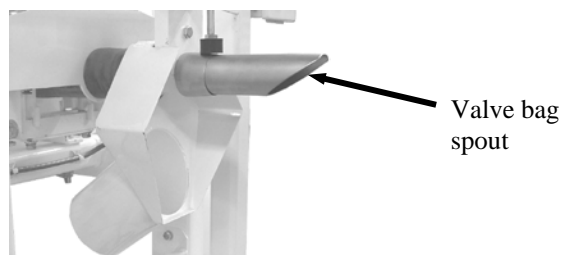

Figure 1-5. Valve Bag Spout

## General Description

### 1.7.6.2 Open Mouth Bag Spout

The Model IPV is also available with an open mouth bag spout. This style of spout is used to fill open mouth bags. This type of spout uses an inflatable neck seal to seal the gap between the spout and the bag during the fill cycle. The inflatable neck seal is used for two purposes:

- Prevent leakage of the product and any dust from exiting through the gap between the spout and package.
- Hold the bag on the spout during the fill cycle.



**Figure 1-6.** Open mouth bag spout

When an open mouth bag spout is used, a blow out switch will be mounted on the rear of the spout to prevent the neck seal from being over inflated. The switch is equipped with a wire bale that is attached to a rotary switch mechanism.

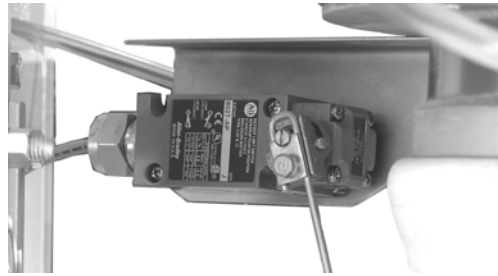
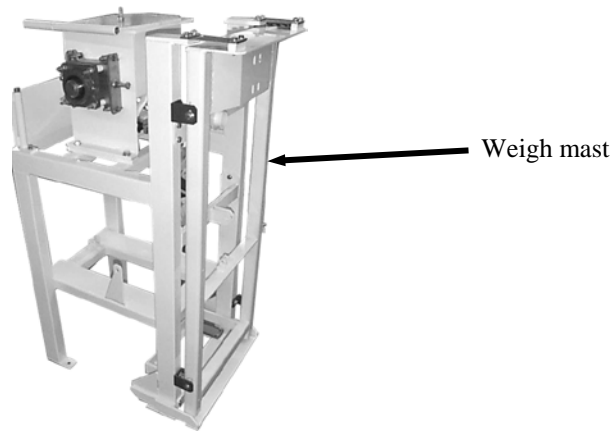

**Figure 1-7.** Blow Out Switch

The open mouth spout also uses a pressure switch for the inflatable neck seal to determine when sufficient pressure has been reached in the neck seal. Once sufficient pressure is achieved, the MAC valve is closed to shut off the supply air to the neck seal.

### 1.7.7 Weigh Mast

The weigh mast hangs from the load cell. It supports the spout. As the package fills, the weight of the entire weigh mast increases.



**Figure 1-8.** Weigh Mast

### 1.7.8 Flex Leaves

The unit uses four flex leaves to stabilize the weigh mast so the load is transferred to the load cell in a consistent linear manner. There are two flex leaves on the top of the weigh mast and two at the bottom.

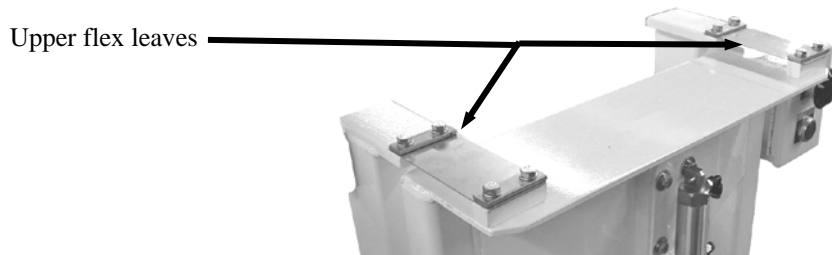

**Figure 1-9.** Upper Flex Leaves

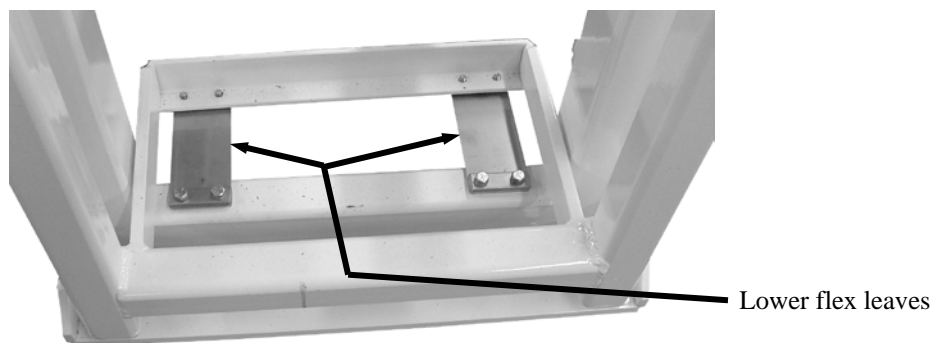

**Figure 1-10.** Lower Flex Leaves

### 1.7.9 Dust Shroud

The standard Model IPV, which has a valve bag spout, comes equipped with a dust shroud to assist in capturing any dust that escapes from the package during the fill cycle. The dust shroud is mounted on the rear of the valve bag spout. The dust shroud has a hole that the rear portion of the valve bag spout passes through. The dust shroud is equipped with a 4-inch tube that an exhaust hose can be connected to.

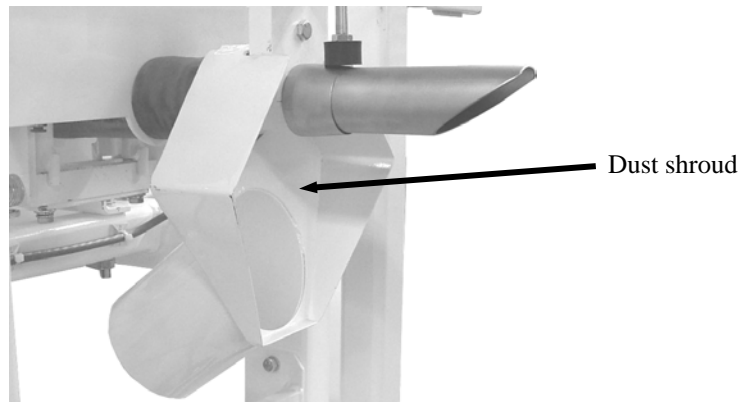

**Figure 1-11.** Dust Shroud

### 1.7.10 AC Motor

The Model IPV is available with either a 230-volt, single-phase, or a 460-volt, 3-phase, 60 Hz AC motor. Both motors are 7 ½ Hp units. This motor drives the impeller via a dual drive belt drive setup.

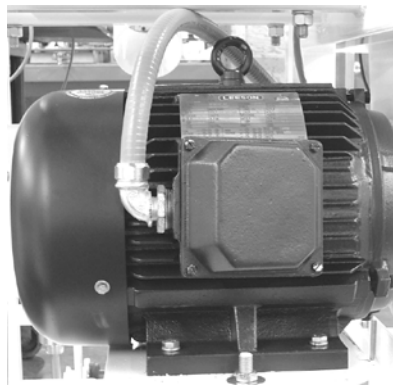

**Figure 1-12.** AC Motor

### 1.7.11 Drive Belts

The impeller is driven by a dual drive belt system. A small dual groove pulley on the AC motor drives a large dual groove pulley on the impeller shaft.

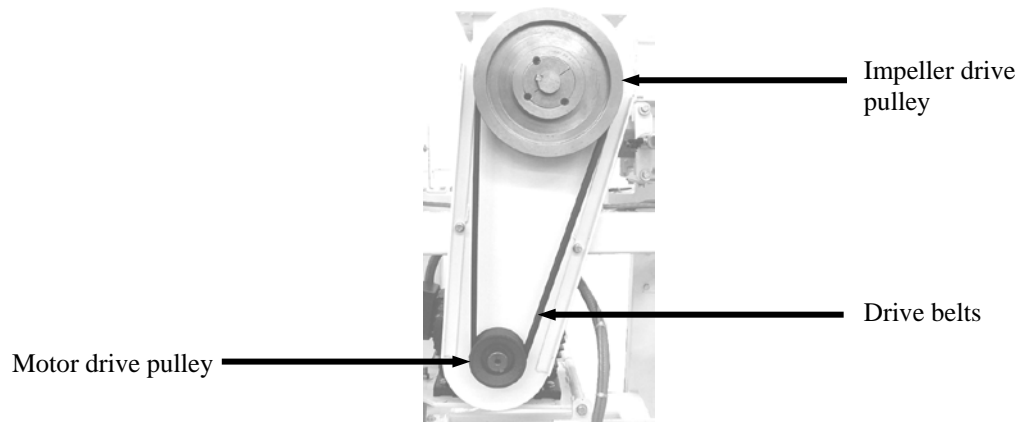

**Figure 1-13.** Drive Belt System

### 1.7.12 MAC Valves

There are several MAC valves that are mounted on the rear of the Model IPV. These valves are used to control various pneumatic components on the Model IPV, such as the dribble and cutoff gates.

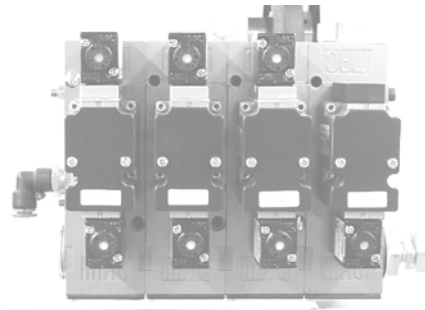

**Figure 1-14.** MAC Valves

### 1.7.13 Bag Clamp

A pneumatic bag clamp is used in conjunction with the valve bag spout to hold the valve bag on the spout. It is engaged and disengaged by a MAC valve.

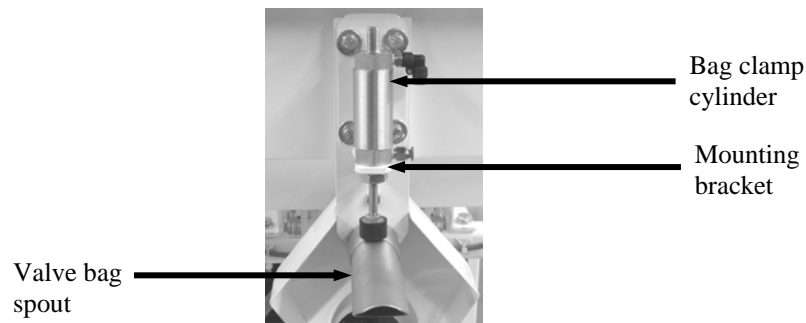

**Figure 1-15.** Bag Clamp

### 1.7.14 Bag Clamp Actuator Switch

The bag clamp actuator switch is a rotary type switch. It is equipped with a metal bale that is attached to the rotary switch. As the operator places the bag on the spout, their hand will contact the bale. This will cause the rotary switch to turn and momentarily complete the circuit. The output from this switch results in the bag clamp being applied for machines equipped with the valve bag spout. For machines equipped with the open mouth bag spout, the output from this switch will cause the inflatable neck seal to inflate. Shortly after, the fill cycle will start.

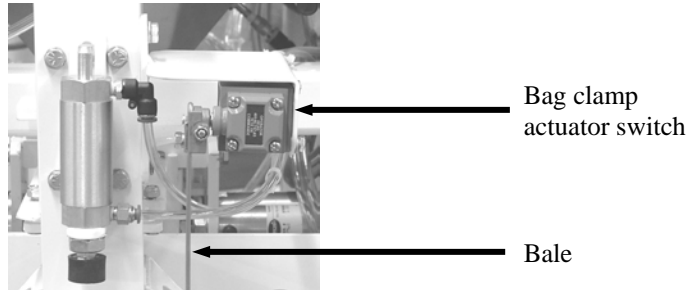

Figure 1-16. Bag Clamp Actuator Switch and Bale (Valve Bag Application)

### 1.7.15 Adjustable Pinch Valve

The Model IPV controls the bulk feed rate with air pressure. Once SP1 (dribble weight) has been reached, the Model IPV switches to the dribble rate by actuating an adjustable pinch valve. The adjustable pinch valve consists of one pneumatic cylinder that is mounted vertically above the fill tube. When the cylinder is actuated, it causes two arms to pinch the fill tube so that the feed rate is reduced. The amount of product flow during the dribble period can be adjusted using the adjustment knob on top of the pinch valve assembly. Turning the knob clockwise will reduce the flow of product. Turning the knob counter-clockwise will increase the flow of product.

Once SP2 (cutoff weight) has been reached, the Model IPV will actuate the adjustable pinch valve all the way closed to stop the flow of product. At the same time, the Model IPV will stop the impeller.

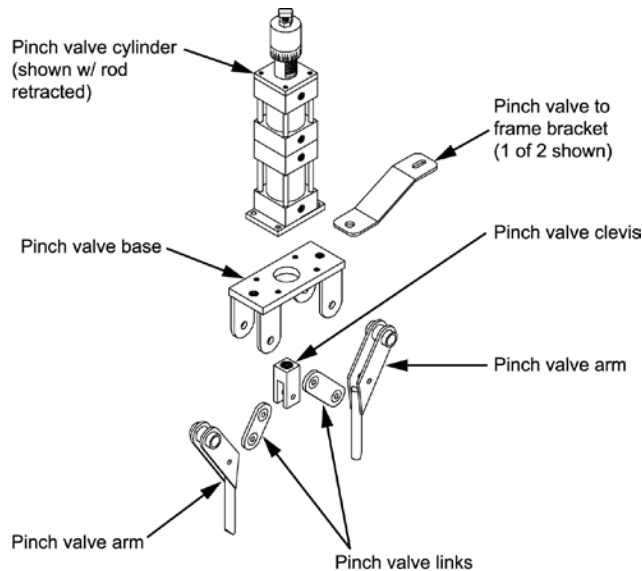
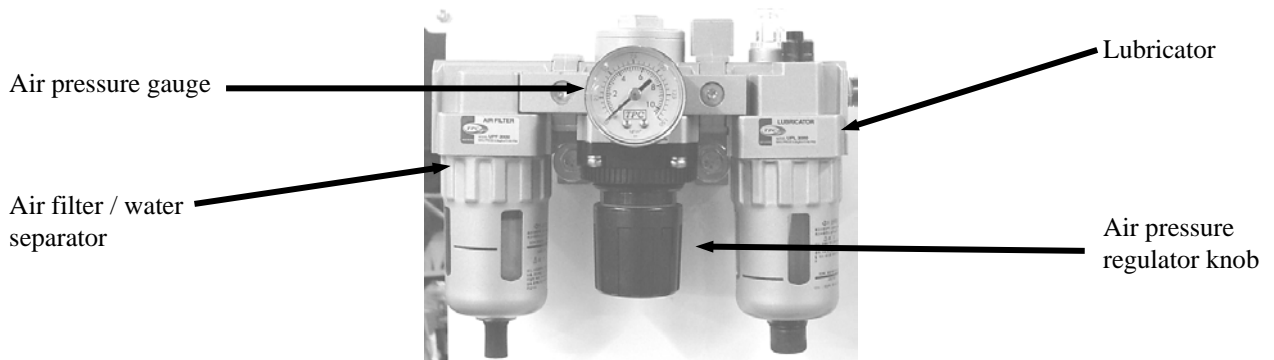

Figure 1-17. Adjustable Pinch Valve

### 1.7.16 Filter/Regulator/Lubricator (FRL) Assembly

The compressed air filter/regulator/lubricator (FRL) is located on the rear of the unit. The compressed air enters the air filter, where the moisture content of the air is reduced. After the filter, the pressurized air enters the regulator. The operator can adjust the air pressure using the air pressure regulator knob. At the maximum setting, the air leaving the regulator will be at the same pressure as the air entering the regulator. Output air pressure is displayed on the air pressure gauge. After leaving the regulator, the air goes through the lubricator chamber, where a lubricant is atomized in the compressed air.



**Figure 1-18.** Air Filter/Regulator/Lubricator (FRL)

### 1.7.17 Bag Kicker

For Model IPV machines that are equipped with a valve bag spout, an optional kicker is available to remove the filled packages from the spout. The kicker is controlled using a pneumatic cylinder.

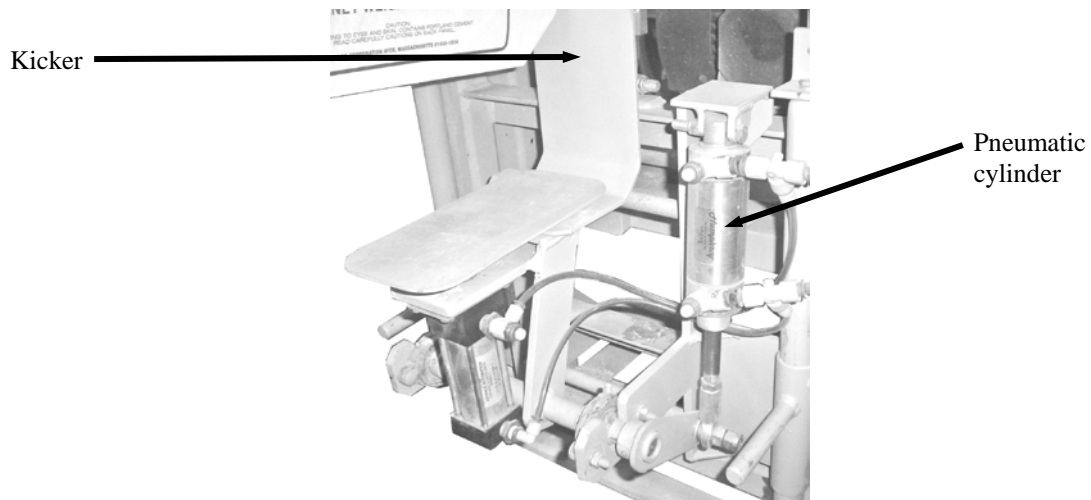

**Figure 1-19.** Kicker

General Description

### 1.7.18 Bag Settlers

An optional feature of on the Model IPV is the settler. The settler is used for two purposes:

- To assist the product being packaged to settle
- To assist the kicker in pushing the filled package onto a conveyor:

As the package is filling, the pneumatic cylinder is extended and retracted mulIPVle times. This causes the pad on the end of the settler to push the bottom of the bag up and then release. This motion helps the product settle in the bag.

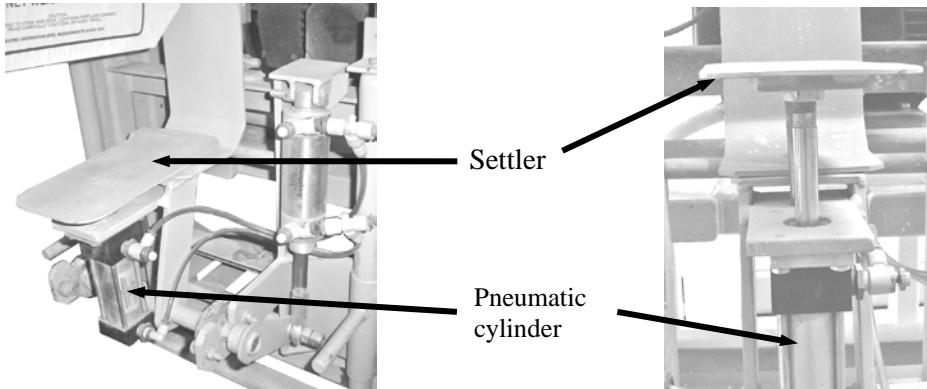
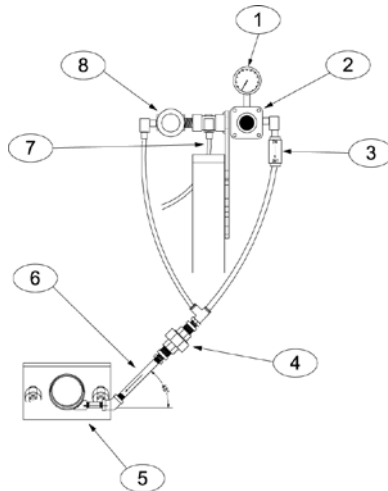

Figure 1-20. Settler

### 1.7.19 Bleed Air Control System

The Model IPV utilizes a bleed air control system to prevent the product from clogging up in the discharge spout. The bleed air control system uses clean, filtered compressed air that DOES NOT have lubrication added to it. The incoming air is fed to the bleed air pressure regulator and to the palm valve.



Item #	Description	Item #	Description
1	Regulator gauge	5	Discharge spout
2	Regulator assembly	6	Bleed air feed tube
3	Check valve	7	Incoming air supply
4	Porex filter	8	Palm valve

Figure 1-21. Bleed Air Control System

The bleed air pressure regulator is used to control the amount of air that is supplied to the discharge spout during the fill cycle. This setting is typically 4 to 6 PSI (.03 to .04 MPa).

If a clog develops in the spout, the palm valve can be pressed to direct high-pressure air to the discharge spout to help dislodge the clog.

The bleed air control system also uses a Porex filter wafer to remove any debris or contaminants from the air prior to entering the discharge spout.

## 1.7.20 Machine Controls

The Model IPV comes standard with a T4000 control panel, but can be ordered with a T3000 control panel. All configuration and control adjustments are made using the control panel.

### 1.7.20.1 Control Box With T4000 Control Panel

The Model IPV comes standard with a T4000 control set. The T4000 uses different levels of voltage to monitor and control the weighments. The T4000 units are available in either a single set point model or a dual set point model. A single set point unit uses one fill rate. A dual set point unit uses two fill rates, bulk rate and dribble rate.

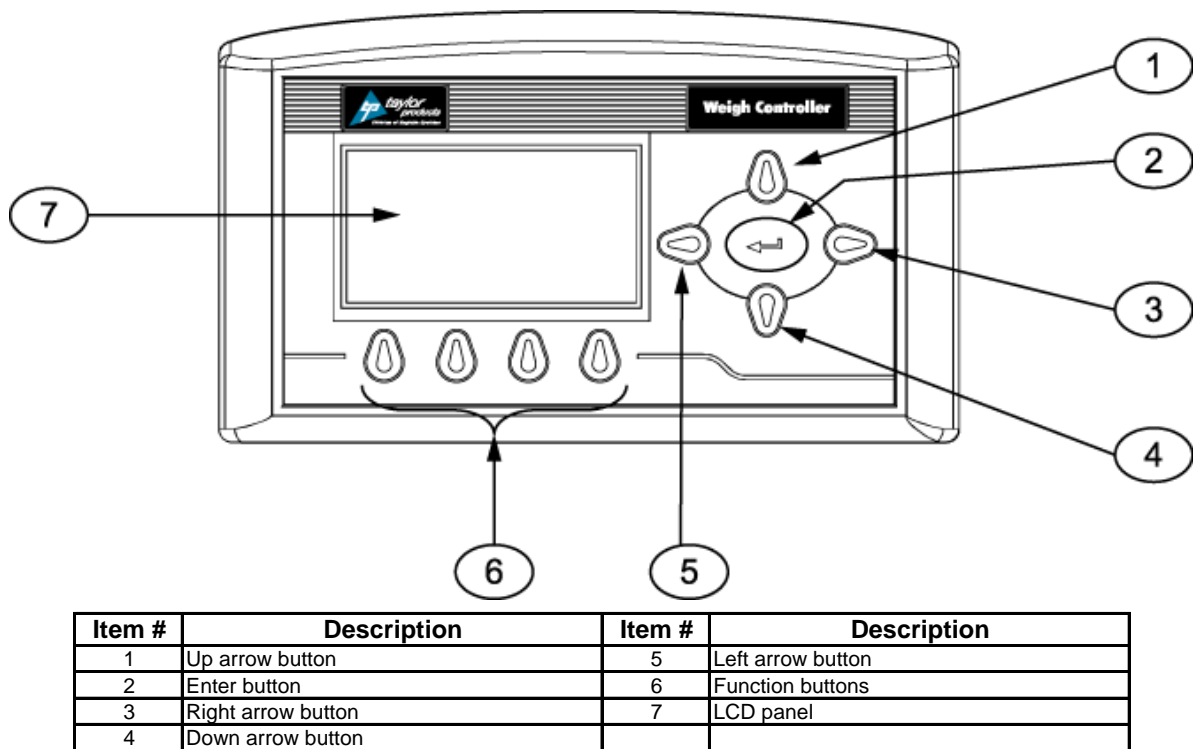

Figure 1-22. T4000 Faceplate

The T4000 has an operating range of  $-10^{\circ}\text{C}$  to  $40^{\circ}\text{C}$  ( $14^{\circ}\text{F}$  to  $104^{\circ}\text{F}$ ). As temperatures approach the lower end of the operating range, the display will start to look "slow". This is the display that is slowing down. The internal electronics are still operating at their default rates.

## General Description

The control box has other manual controls that the operator will also use to control machine functions. The operator controls consist of the following items:

- T4000 Control Panel
- KICK/HOLD button
- POWER ON indicator
- POWER switch



**Figure 1-23.** Control Box With T4000 Control Panel

### 1.7.20.2 Control Box With T3000 Control Panel

The Model IPV is available with an optional Taylor T3000 control set. The T3000 has the ability for total monitoring and instrument control. This control set allows the operator to monitor and control the Model IPV. The T3000 units are available in either a single set point model or a dual set point model. A single set point unit uses one fill rate. A dual set point unit uses two fill rates, bulk rate and dribble rate.

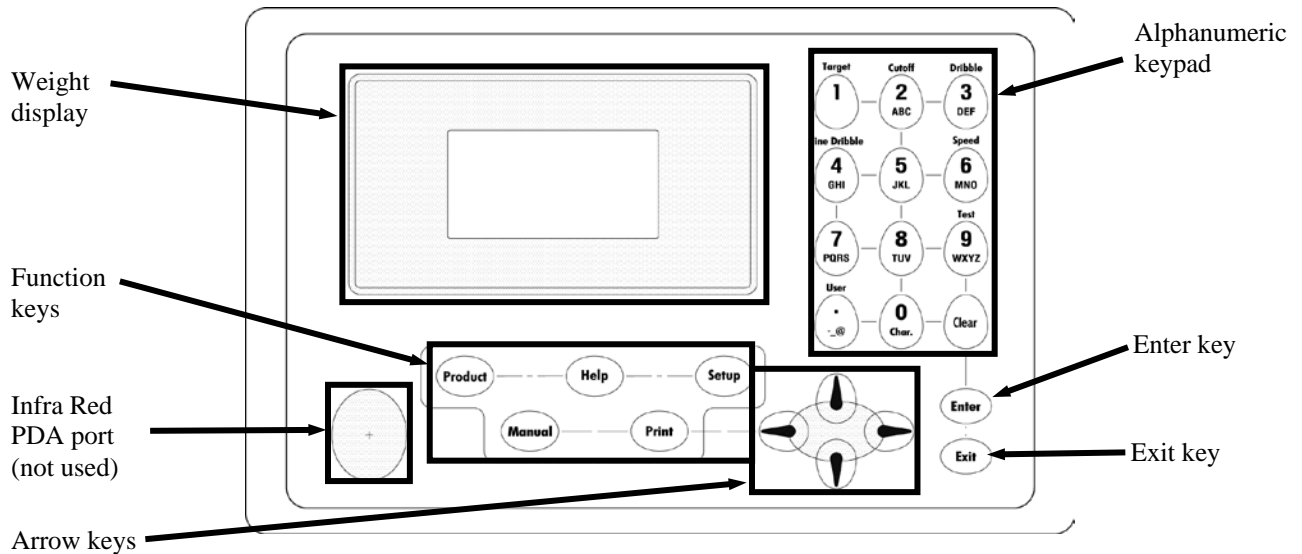

**Figure 1-24.** T3000 Faceplate Layout

The T3000 has an operating range of  $-10^{\circ}\text{C}$  to  $50^{\circ}\text{C}$  ( $14^{\circ}\text{F}$  to  $122^{\circ}\text{F}$ ). As temperatures approach the lower end of the operating range, the display will start to look "slow". This is the display that is slowing down. The internal electronics are still operating at their default rates.

The operator controls consist of the following items:

- T3000 control panel
- KICK/HOLD button
- Power switch
- POWER ON indicator

# General Description

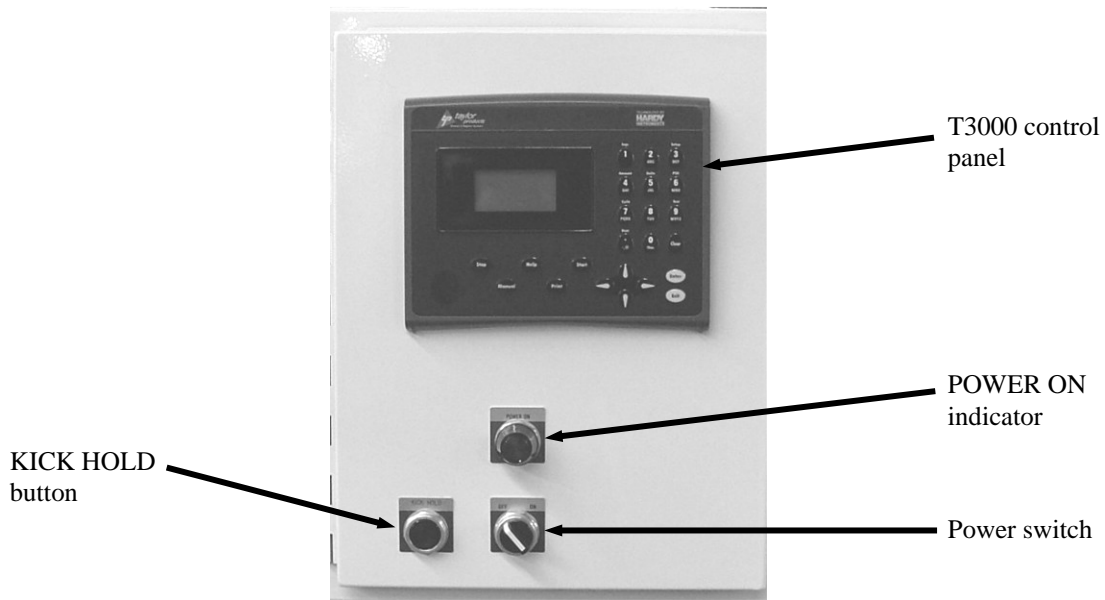

**Figure 1-25.** Example of Model IPV Control Panel with T3000

## Chapter 2

# Receiving Equipment

### 2.1 General Description

Immediately upon receiving the equipment, inspect each unit carefully to make sure each item is in good condition and that all items on the packing list have been received. Each unit has been packaged for protection during normal shipping and handling. However, it is possible that the equipment has been damaged in transit. Note any damages or shortages on the Bill of Lading. Immediately file damage reports and damage claims with the Carrier. Any and all damage to the equipment that occurs in transit is the responsibility of the Carrier, as it is the Manufacturer's (Magnum Systems) standard policy to ship all equipment F.O.B. from our factory. This means that ownership of the equipment changes from the Manufacturer to the Purchaser, at the time the Carrier loads and accepts the equipment. Therefore, any claims for losses or damages that occur in transit must be made to carrier by Purchaser.

### 2.2 Uncrating the Equipment

Follow the steps below to uncrate the Model IPV.



#### **WARNING**

*Use care when unpacking the Model IPV to avoid damage to any hinged parts and external controls.*

*Grasp the Model IPV by the Base Frame to handle.*

*Do not pick up the Model IPV by lifting on the Bag Spout or weigh mast.*

*Do not drop the Model IPV on the Bag Spout.*

*Blunt trauma, strain, and torque can cause Load Cell failure! The load cell is not covered under the Magnum Systems warranty.*

1. The Model IPV should be installed on a level concrete floor in a cleared area that is at least 4' x 6'.

***Important:*** *It is recommended that the Model IPV be located directly under the supply hopper. Complete any nearby construction before installing the Model IPV.*

2. Upon receiving the shipment, inspect the crate for any visible damage. Pry the crate open, using a crowbar.

***Important:*** *Before removing the Model IPV from the shipping pallet, inspect the unit for visible damage. Inspect for damaged or missing parts. If there is damage, notify the shipper and Magnum Systems immediately.*

3. Cut the metal bands. Remove the lag bolts from base frame at pallet.
4. Grasp the Model IPV by the base frame to handle. Use the fork pockets to lift the Model IPV off of the pallet with a forklift.

## Receiving Equipment

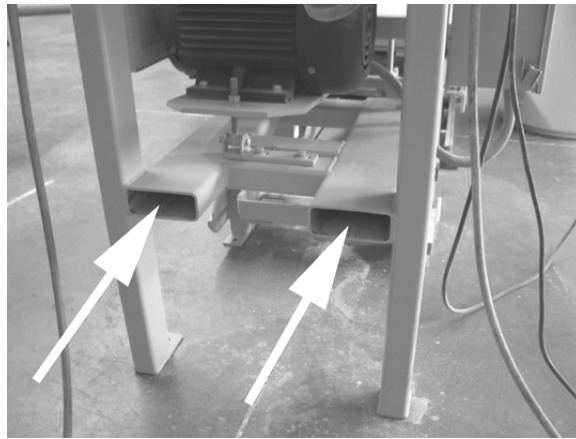

**Figure 2-1.** Model IPV Fork Pockets (Arrows)

5. Remove and discard all of the crating material.
6. Remove the four shipping angle bracket mounting bolts and brackets from Model IPV. Reverse the shipping brackets, and bolt them back onto the main frame for storage.



**Figure 2-2.** Shipping Brackets Connecting the Weigh Mast to the Main Frame

7. Confirm that the Model IPV is level. If necessary, anchor the feet to the floor with four 3/8"-16 x 1 1/2" anchor bolts for added stability.
8. Cut and remove the plastic ties from the control panel.

## Chapter 3

### Setup/Installation

#### 3.1 General Description

Only persons who have been properly trained and hold the appropriate qualifications should attempt to install, operate, or maintain this equipment.

**WARNING**

*Before installing, adjusting, or servicing any electrical component, be sure to become familiar with the electrical schematic for the machine.*

**WARNING**

*Before installing, adjusting, or servicing any pneumatic component, be sure to become familiar with the pneumatic schematic for the machine.*

#### 3.2 Mechanical Setup

When setting up a Model IPV, special care must be taken to follow the installation procedures to achieve optimum performance and eliminate any vibration.

Once the Model IPV has been moved into the position where it will operate, follow the steps below to setup the mechanical components for operation.

1. Use shims under the legs of the Model IPV to ensure that the frame is level. If the frame is not level, the performance of the Model IPV will be adversely affected.
2. Make sure the weigh mast is plumb and level.
3. Make sure the flex leaves are level. The flex leaves must not be angled downward or upward. This would lead to inaccurate weighments. Adjust the angle of the flex leaves by adjusting how high or low the load cell allows the weigh mast to hang.

##### 3.2.1 Supply Hopper

Design the supply hopper installation to ensure a constant and uniform flow of material to the Model IPV. Good hopper design will enhance the efficiency and accuracy of the Model IPV. Hopper design will depend on the flow characteristics of the material being handled. Follow the steps listed below to install the supply hopper.

*Note: Testing may be required for unfamiliar or problem materials.*

**WARNING**

*A neoprene or other suitable gasket should be installed between the material supply hopper and the mounting flange of the Model IPV.*

**WARNING**

*When mounting the material supply hopper to the Model IPV, take special care to isolate the supply hopper. Isolating the supply hopper will prevent outside vibration from reaching the weigh controller, which can cause inaccurate weighments.*

## Setup/Installation

**Note:** The hopper inlet flange is welded to the top of the main body of the Model IPV. The hopper inlet flange has a 10<sup>3</sup>/<sub>4</sub>" X 10<sup>3</sup>/<sub>4</sub>" center opening and a 13" X 13<sup>1</sup>/<sub>4</sub>" outside flange dimension.

1. Position the Model IPV hopper inlet flange directly below the supply hopper outlet flange.
2. Fit the white neoprene gasket (or product suitable gasket) between the inlet and outlet flanges.
3. Lower the supply hopper so that it is snug on Model IPV outlet flange. Check that the fit is flush and level.
4. Secure the connection using twelve 3/8"-16 x 1<sup>1</sup>/<sub>2</sub>" hh bolts, nuts, and split lock washers.

### 3.2.2 Dust Conduit for Supply Hopper

If the bagging process will generate dust, the conduit fittings must be dust-tight and satisfy any hazard requirements for the product and site.

Use the 4-inch O.D. Dust Pickup Spout on the back of the dust shroud to connect the Model IPV to a dust collection system. The dust collection duct should have a blast gate to control the flow of air at the spout.

**Important:** Excessive airflow could create vacuum forces at the spout and affect weights.

## 3.3 Electrical Connections

Before connecting the Model IPV to the electrical supply, it is vital that the unit be properly grounded. The recommended method is to plug the power cord into an earth grounded receptacle.

The Model IPV requires two different voltages for it to operate. The controls require 115 VAC at 50 or 60 Hz, single-phase power. The standard impeller motor requires a 230 VAC, 3-phase, 60 Hz unit power source. An optional impeller motor is available that requires 460 VAC, 3-phase, 60 Hz power. The Model IPV should be placed within 6 feet of the electrical outlets that it will be connected to.

Always refer to the electrical drawings in Appendix D for exact voltage requirements.

## 3.4 Pneumatic Connections

The Model IPV requires an air supply line that is capable of consistently delivering 90 PSI (.62 MPa) at 5 CFM (142 liters) for proper operation. Magnum Systems recommends that the air supply line be equipped with a refrigerated air dryer, or at the very least a water separator.

The air filter/regulator/lubricator has a 1/4-inch NPT female thread on the inlet and outlet side. The buyer will need to supply the inlet fitting. It is recommended that Teflon<sup>®</sup> tape be used on the threads to assist in sealing. The output side is equipped with a quick connect fitting from the factory. After making pneumatic connections, check all connectors for leaks using a soapy water mixture. Bubbles will appear at the site of any leaks. Eliminating or reducing air leaks will reduce wear on the air supply equipment.

## 3.5 Making Network Connections

Model IPV units that are equipped with the optional T3000 control set have the ability for total monitoring and instrument control via the built in communication connectivity of the T3000. The T3000 has the following network capabilities:

- DeviceNet
- HardyLink Ethernet
- IR Port
- RS-232 Simplex Serial Port
- Remote I/O (RIO) (optional)
- ControlNet (optional)
- Profibus I/O (optional)
- Modbus over TCP/IP (optional)
- OLE Process Control (OPC) (optional)

## 3.6 Security Settings

The manager has the ability to control who does and who does not have the ability to change system and calibration settings, regardless of the type of control panel that the machine is equipped with. However, the process for setting the security parameters varies by controller type. The Security parameters allow management to place security on the instrument and any menu or sub-menu requiring a password before enabling any changes. The Change Security parameter enables all persons to see the security status for a given menu, and selected persons to change that security status for any menu.

### 3.6.1 T4000 Security Settings

To setup security in the T4000 control panel, use the following steps:

1. From the Standby screen, press the function button below MENUS.
2. The Configuration menu will appear. Press the down arrow until the cursor is in front of Security.

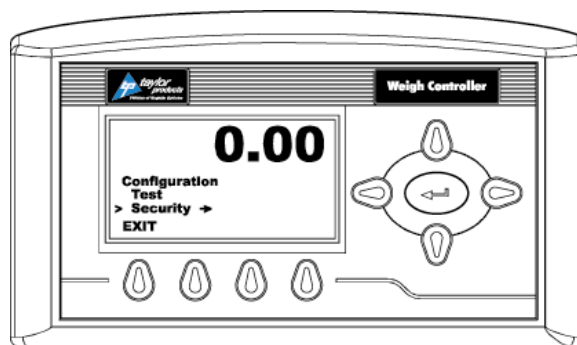
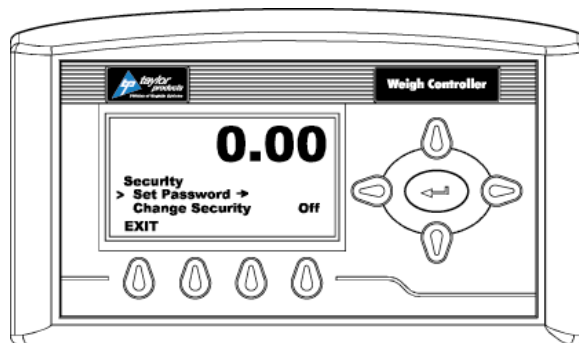

**Figure 3-1.** Placing The Cursor In Front Of Security

3. Press the enter button. The Security menu appears.
4. Set the Password Parameter. The Set Password parameter enables the operator to create a password for entry to secure menus and sub-menus. If the password is 0 there is no security. If the password is anything other than 0 the security is enabled.

**Note:** It is recommended that the passwords be created before setting security on the various menus.

5. Press the down arrow button until the cursor is in front of Set Password.



**Figure 3-2.** Placing The Cursor In Front Of Set Password

6. If the password is being set for the first time or if the factory defaults have been reset in the Test menu, enter the default password “2205”. If the password is being reset, and the existing password is known, enter that number. Press the enter button. The Verify Password display appears.
7. Press the enter button. If the password is correct a brief message “Entry Accepted” appears and the Set Password display with the current password appears.

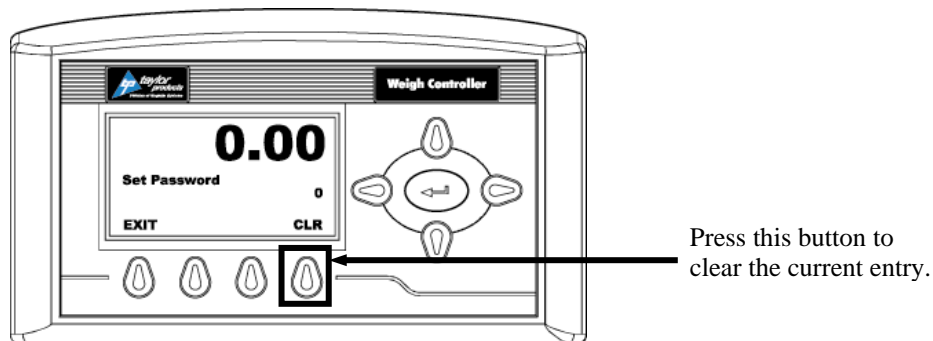

**Figure 3-3.** Set Password Menu

8. Press the function button located directly below the CLR item on the display to clear the entry. Use the left or right arrow buttons to move the cursor left and right. Use the up or down arrow buttons to enter the password number. To delete a single entry, press the left arrow button. In the example below, “123” was entered.

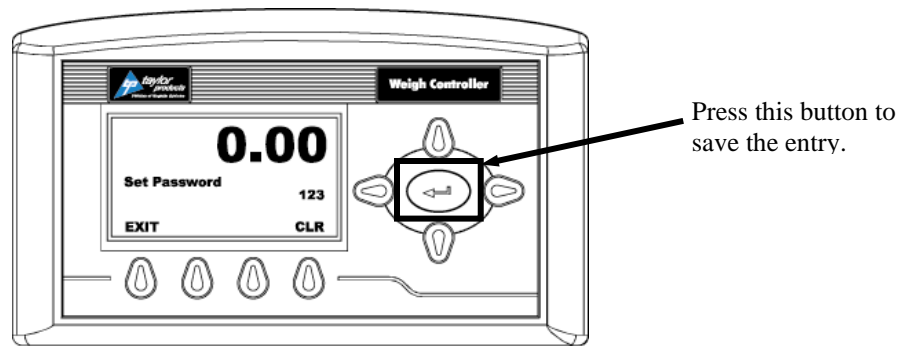

**Figure 3-4.** Password Set To 123

9. Press the right or left arrow buttons to toggle Change Security On. The Verify Password display appears.

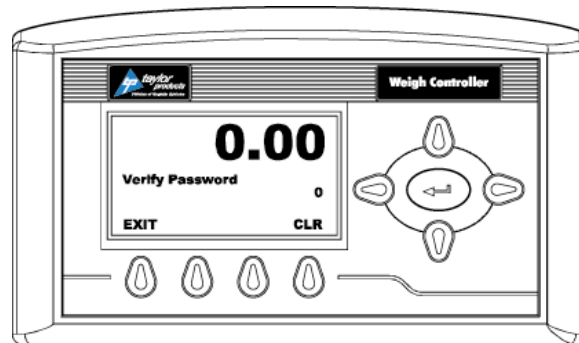

**Figure 3-5.** Verify Password

10. Use the left or right arrow buttons to move the cursor left and right. Use the up or down arrow buttons to enter the password number.

**Important:** When entering the password, the last digit is entered first, then the next digit to the left and so on. For example, if the password is set to 123, then 3 is entered first, then the 2, and the 1 is entered last.

11. Press the enter button. The Change Security status changes to On. In this instance we turned Change Security ON because we want to change the security of a sub-menu.
12. Now that the Change Security On feature has been turned on, press the function button below the word EXIT on the display to return to the Configuration menu.
13. Use the up or down arrow buttons to go to the desired sub-menu to be secured. In the example below, the Decimal Point sub-menu has been selected. Notice that the display now includes a SECUR menu item above the function buttons.

**Note:** Steps 8-12 will need to be repeated to lock and unlock a parameter.

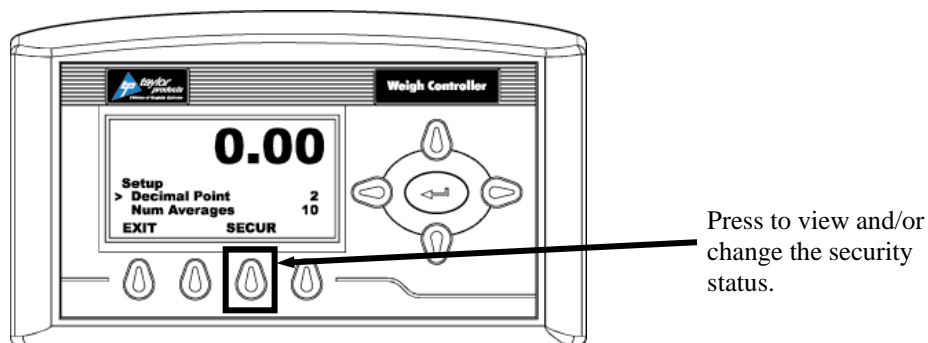

Figure 3-6. SECUR Menu Item Shown Above Function button

14. Press the function button that is positioned below the SECUR item on the display, to view and/or change the security status of this parameter.
15. Press the right arrow button to changed to LOCKED thereby securing this sub-menu.

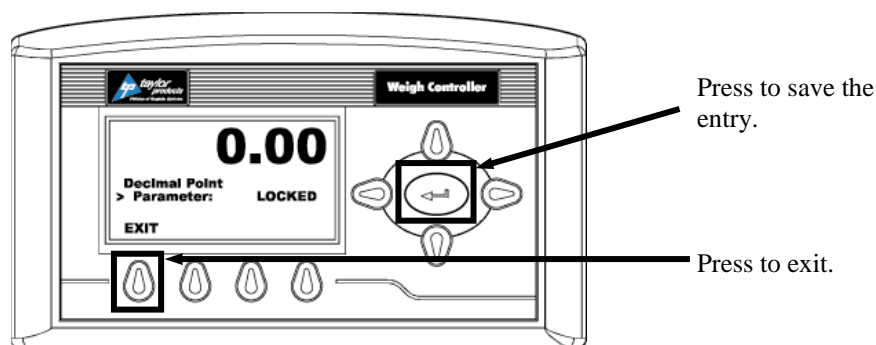

Figure 3-7. Parameter Shown Locked

16. Press the enter button to save the entry.
17. Press the function button below EXIT on the screen until the summary display is shown.

*Note: To check to see if the security is set on a specific sub-menu, press the EXIT button until the summary display appears. Then re-enter the menus and try to change the secure parameters.*

18. Until security has been changed, changing this parameter will require a password (other than 0) to be entered.
19. To turn the Change Security OFF, go back to the Security menu and repeat steps 1-6.

### 3.6.2 T3000 Security Settings

The T3000 has three levels of system security:

- Low – No password required
- Medium – A password is required to access some, but not all of the top level menus
- High – A password is required to access all top-level menus.

Additionally, the manager also has the ability to assign different levels of security to individual menus. The menus where this applies are:

- Adjust Ingredient
- Setup
- Calibration
- Options
- I/O Mapping

If a menu has a security setting of Medium or High, the users' access will be read-only, unless they enter the correct password.

Follow the steps below to set security.

1. Press the User shortcut key. Enter the User ID and high-level password.
2. From the Standby display, press the Setup button. The Configuration Menu will appear.
3. Use the up/down arrows to position the cursor in front of SECURITY. Press the Enter button.
4. The SECURITY MENU will appear. The cursor will be in front of SET SECURITY MENU selection. Press the Enter button.
5. The SET SECURITY MENU will appear. The Top-Level Menus will be listed with the security level set at the default LOW setting.
6. Press the up/down arrow buttons to position the cursor in front of the desired menu selection.
7. Press the left/right arrow buttons to change the security setting for that menu item.
8. Once the desired security level is displayed, press the Enter button to set the entry.
9. If other menus require an adjustment to its security setting, repeat steps 5 through 7.
10. When all security setting adjustments have been completed, press the Exit button to return to the Standby display.

## 3.7 Dry Cycle

Once all electrical and pneumatic connections have been made, the operator should dry cycle the machine to test the control components. If all components operate properly, the machine is ready to calibrate.

**Important:** *During the dry cycle process, the hopper should be empty.*

**Note:** *The cylinders may be cycled manually by pressing the test buttons on the solenoid valves.*

1. Turn the power switch on the control panel of the Model IPV to the ON position.
2. Make sure that the air pressure on the FRL is set to specification.
3. Trip the bag clamp actuator switch. This should result in the following actions:
  - For machines with a valve bag spout, the bag clamp will extend and the bag clamp pad should come in contact with the spout.
  - For machines with an open mouth bag spout, the inflatable neck seal should inflate.
  - The kicker (if equipped) will retract to the down position.
  - The settler (if equipped) should cycle up and down.
  - The adjustable pinch cylinder will extend to open the fill tube.
4. Press the STOP button to simulate the package reaching target weight. This should result in the following actions:
  - The adjustable pinch cylinder will retract to close the fill tube.
  - For machines with a valve bag spout, the bag clamp will retract.
  - For machines with an open mouth bag spout, the inflatable neck seal will deflate.
  - The settler (if equipped) will retract.
  - The kicker (if equipped) will extend.
  - The butterfly valve actuator will open the butterfly valve.

## 3.8 Calibration

Each Model IPV is calibrated prior to leaving the factory. However, the unit should be reassessed before first use of the unit. It is recommended that the calibration of the unit should be checked every week or anytime that a new load cell is installed, or if any other changes are made that affect the weigh system. A certified test weight must be used to check the calibration of the Model IPV.

*Note: Make sure that the shipping brackets have been removed before beginning the calibration process.*

### 3.8.1 Calibrating the T4000 Control Panel

The calibration procedure for a T4000 control set is listed below:

1. Make sure the T4000 has been configured for the intended application. This includes setting the units, decimal point, scale capacity, averages, etc.
2. From the Summary display press the enter button. The Configuration menu appears.
3. Press the down arrow button until the cursor is in front of Calibration.
4. Press the enter button. The Calibration menu appears.
5. Traditional Calibration is the method of calibration that uses test weights. Magnum Systems recommends that the test weights total 80–100% of the desired package weight, and that the weight be distributed uniformly on/in the scale.
6. From the Summary display, press the enter button. The Configuration menu appears.
7. Press the down arrow button until the cursor is in front of the Calibration line.

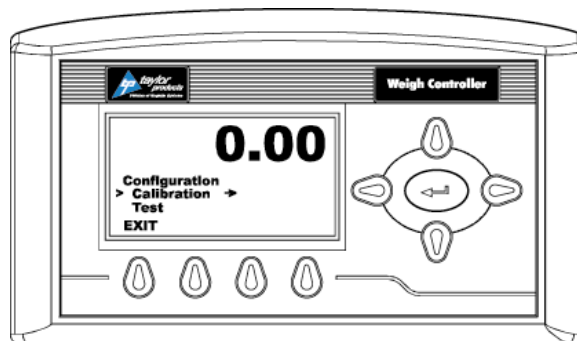

**Figure 3-8.** Placing the Cursor In Front Of Calibration

8. Press the enter button. The Calibration menu appears.
9. Press the down arrow button until the cursor is in front of “Trad Cal”.

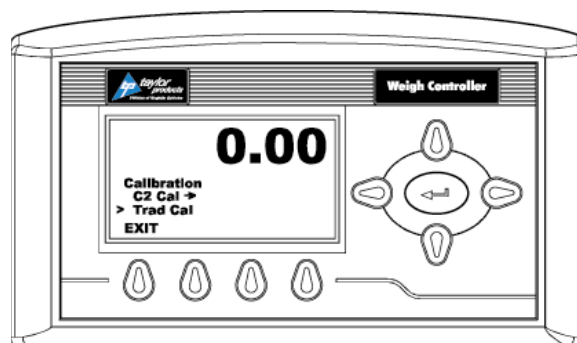

**Figure 3-9.** Placing The Cursor In Front Of Trad Cal

10. Press the enter button. The Trad Cal menu appears.

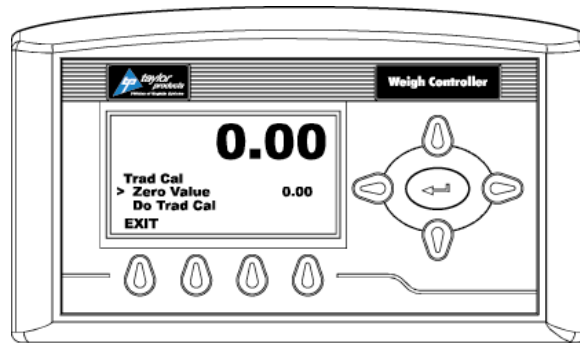

Figure 3-10. Placing The Cursor In Front Of Zero Value

11. Press the enter button. The Zero Value weight menu appears.
12. Traditional Calibration requires a zero point and the physical placement of test weights on the scale. To set the Zero Value Weight:
  - a. Remove all weight “live load” from the Scale. The Zero Value should be 0.0.



**CAUTION** The scale MUST be empty.

- b. Wait 12 seconds or more.
13. Use the left and right arrow buttons to position the cursor. Use the up or down arrow buttons to enter the Zero Value for this instrument.

*Note: Most applications will set the Zero Value to 0.00.*

14. Press the enter button to save the entry.
15. Press the down arrow button until the cursor is in front of “Do Trad Cal ” (Zero)”.
16. Press the enter button to Do the Cal Trad Cal (Zero).
  - a. A “Cal Completed OK” message appears briefly if the calibration was successful.
  - b. An Error number appears if the calibration was not successful. An Error list is provided with the troubleshooting information later in this guide. Refer to this list in order to correct the error.
17. Press the down arrow button until the cursor is in front of Span Value.
18. Press the enter button. The Span Weight menu appears. The last Span Weight is displayed.

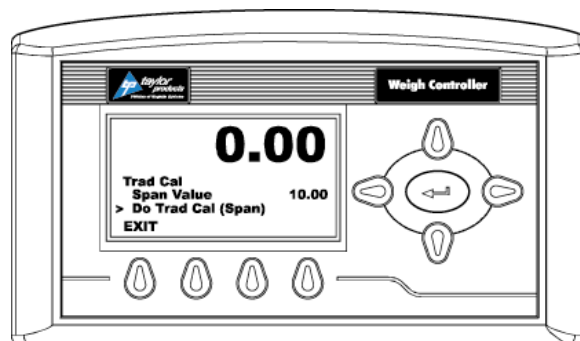

Figure 3-11. Span Value Displayed

19. To set the Span Weight:
  - a. Place a certified test weight on the scale.
  - b. Use the left and right arrows to position the cursor and the up or down arrows to enter the value of the test weight. If a 10 lb. weight is used, enter 10.00.
  - c. Press the enter button to save the entry.
20. Press the down arrow button until the cursor is in front of “Do Trad Cal (Span)”.
21. Press the enter button to Do the Trad Cal (Span).
  - a. A “Cal Completed OK” message appears briefly if the calibration was successful.
  - b. An Error number appears if the calibration was not successful. An Error list is provided with the Troubleshooting information later in this guide. Refer to this list in order to correct the error.
22. The scale is now calibrated.

### 3.8.2 Calibrating the Optional T3000 Control Panel

The Calibration Menu is used to calibrate the weighing system of the T3000.

Before beginning the calibration procedure, be sure that the machine is ready to be calibrated. Make sure that the load points have been installed properly. Follow the steps below to make sure the Model IPV is ready for calibration:

1. Make sure the load system is free of binding and that nothing is draped over the equipment, such as hoses, electrical cords, tubes, etc.
2. Verify that the load cell is mounted so that 100% of the load always passes vertically through the load cell at the same point.
3. Check all communication and power cables to be sure they are securely fastened to their connectors on the rear of the control panel.
4. Make sure that power is supplied to the controller. The panel display should illuminate.

***Important:*** *The operator MUST log in with the proper security level to initiate calibration. Once logged in, an access timer will run. If the timer expires (typically about 5 minutes), the operator will be logged out. The operator will have to log in again to regain access.*

When the operator selects CALIBRATION from the Configuration Menu, the CALIBRATION screen appears. There is one line on that screen, it is the Cal Type line. The currently selected method of calibration will appear at the far right on the Cal Type line. Use the left/right arrow keys to toggle until TRAD is displayed on the line. Press the Enter key to access the screen for the TRAD calibration method.

### 3.8.2.1 TRAD Calibration

This screen will provide the following lines for the operator.

- Zero Value – This value should be set to zero.
- Zero Ct – This parameter is controlled by the controller.
- Do Trad. Cal (Zero) – Start the calibration procedure.
- Span Value – The amount of weight being used for calibration.
- Span Ct – This parameter is controlled by the controller.
- Do Trad. Cal (Span) – Start the calibration procedure.

Use this procedure to calibrate a machine with traditional load cells.

1. Turn on the meter.
2. Press the User shortcut key. Enter the User ID and medium or high-level password.
3. Press the Setup key to access the CONFIGURATION MENU.
4. Use the up/down arrow buttons to scroll to the CALIBRATION line. Press the Enter key to access CALIBRATION.

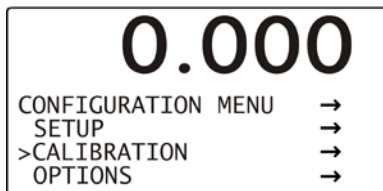

Figure 3-12. Calibration Line

5. Use the left/right arrow keys to toggle to the TRAD selection if it is not already displayed. Press the Enter key.

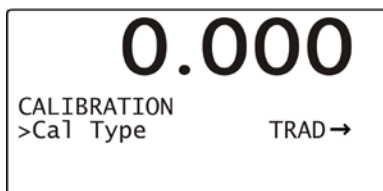

Figure 3-13. Selecting TRAD Calibration

6. A Function OK message will flash briefly in place of the Cal Type line, then the TRADITIONAL CAL screen will appear. Check the display to make sure that the Zero Value reads 0.0.

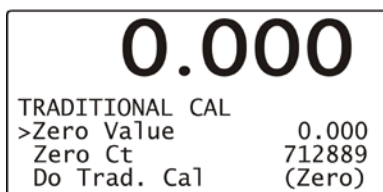
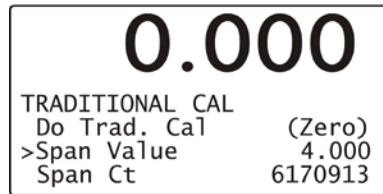

Figure 3-14. Checking Zero Value

7. Use the up/down arrow keys to scroll to the Do Trad. Cal (Zero). Press the Enter key. The weight display will display !Calibration in Progress! and will return to its calibration screen.
8. Use the up/down arrow keys to scroll to the Span Value selection and use the alphanumeric keypad to enter the weight that will be used for calibration. Press the Enter key.



**Figure 3-15.** Setting Span Value

9. Use the up/down arrow keys to scroll down to the Do Trad. Cal (Span). Place the calibration weight on the scale by hanging it on the fill spout directly under the bag clamp cylinder. Press the Enter key. The weight display will display !Calibration in Progress! and will then return to its calibration screen. Press the Exit key three times to return to the main screen.

This Page Intentionally Left Blank

## Chapter 4 Operation

### 4.1 General Description

This chapter will provide detailed descriptions of the operational controls of the Model IPV.

### 4.2 General Fill Cycle Information

A single set point unit has one fill rate. The package is filled using one fill rate until the SP1 weight is reached, then the cutoff gate will close and the impeller will stop. Once the product that is in free fall settles into the package, the package weight should match the target weight.

A dual set point unit has two fill rates, bulk rate and dribble rate. Bulk rate is a faster rate that is used to fill the package quickly, once the package achieves the SP1 weight, the dribble gate cylinders will be extended to slow the fill rate to dribble. Once the package achieves the SP2 weight, then the cutoff gate will close and the impeller will stop. Once the product that is in free fall settles into the package, the package weight should match the target weight.

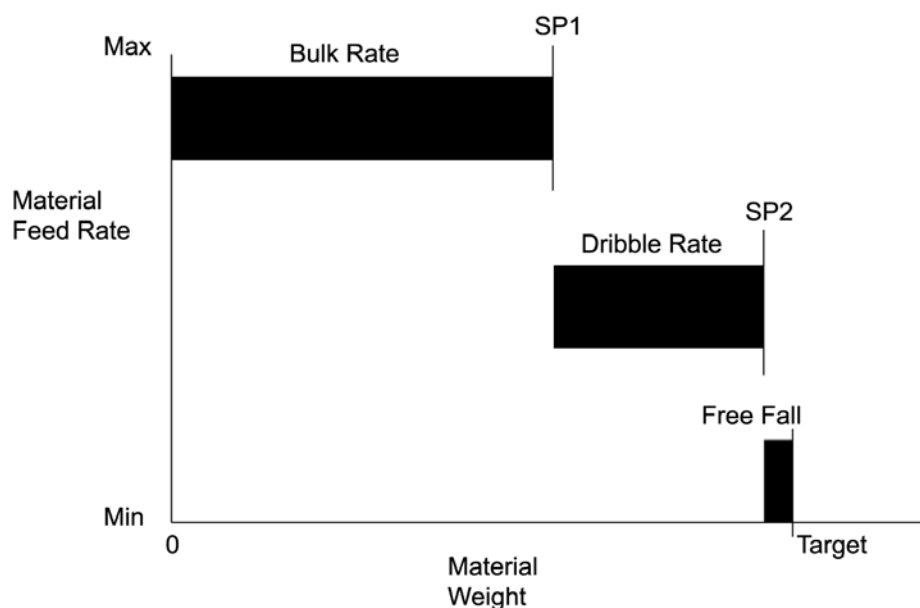

Figure 4-1. Bulk Rate vs. Dribble Rate

#### 4.2.1 Basic Fill Process

The Model IPV will clamp the bag and hold it in place, fill it rapidly, check its weight, and drop the filled bag automatically. The bag clamp jaws are designed to be compatible with most automatic bag hangers to allow for a fully automatic system if desired.

Each type of control panel provides a method of preventing packages from being release if the final weight of the package was outside the acceptable weight range. For example, the desired package weight might be 50 lbs, and the acceptable range is 49.8 to 50.2 lbs. If a finished package weighed 50.5 pounds, the controller would prevent the package from being released until the operator manually intervenes.

## Operation

On machines with the T4000 control panel, this feature is the Target Min/Max menu option. On machines with the T3000 control panel, this feature is the Over/Under Reject menu option. The operator will manually set the points where the package would be considered overweight and underweight. The operator manually sets the overweight and underweight points and if a bag weight is outside of this range, the unit will hold the bag until the operator manually releases the bag by pushing the STOP button. This feature is helpful when there is a sudden change in the bulk density of the material or when the feed bin runs out of material. This guarantees that no bag over or under the allowable weight will be shipped.

### 4.3 Operational Controls

The operational controls will vary, based on the type of control unit and any custom features that have been selected. This manual will focus on the standard analog control units, and the optional digital control unit.

#### 4.3.1 Operation Using Control Box With T4000 Control Panel

The Model IPV comes standard with a T4000 control set. The T4000 uses different levels of voltage to monitor and control the weighments. The T4000 units are available in either a single set point model or a dual set point model. A single set point unit uses one fill rate. A dual set point unit uses two fill rates, bulk rate and dribble rate.

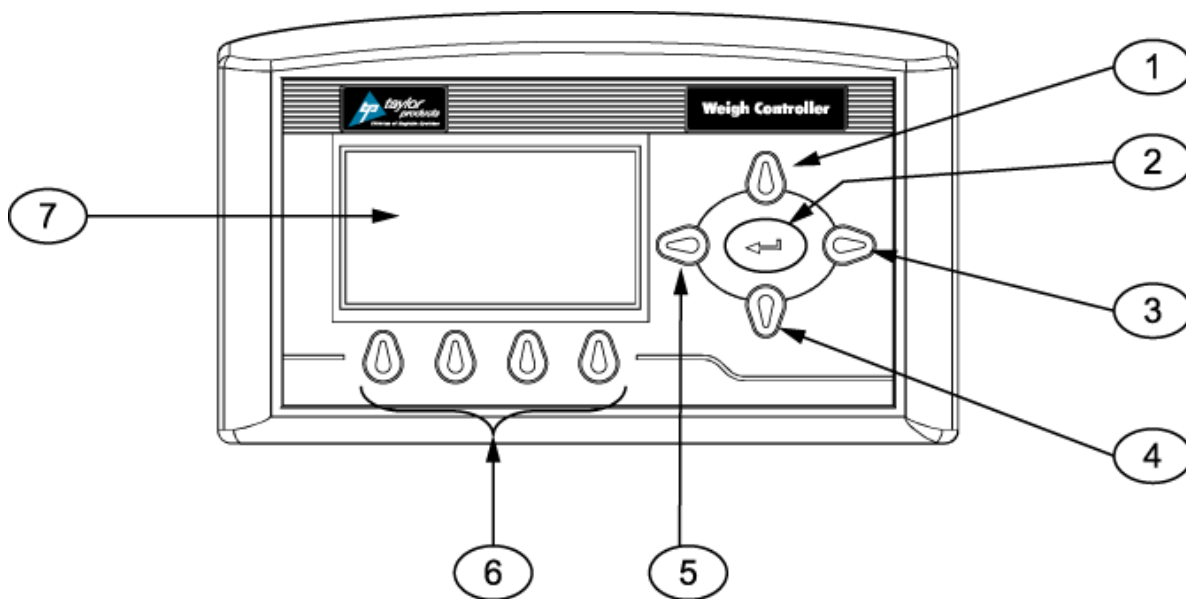

Item #	Description	Item #	Description
1	Up arrow button	5	Left arrow button
2	Enter button	6	Function buttons
3	Right arrow button	7	LCD panel
4	Down arrow button		

Figure 1-2. T4000 Faceplate

The T4000 has an operating range of  $-10^{\circ}\text{C}$  to  $40^{\circ}\text{C}$  ( $14^{\circ}\text{F}$  to  $104^{\circ}\text{F}$ ). As temperatures approach the lower end of the operating range, the display will start to look "slow". This is the display that is slowing down. The internal electronics are still operating at their default rates.

The control box has other manual controls that the operator will also use to control machine functions. The operator controls consist of the following items:

- T4000 Control Panel
- KICK/HOLD button
- POWER ON indicator
- POWER switch



Figure 4-3. Control Box With T4000 Control Panel

### 4.3.2 Operation Using Control Box With T3000 Control Panel

The T3000 control panel uses an electronic display in conjunction with a T3000 control panel that allows the user to make system adjustments and to monitor the system status.

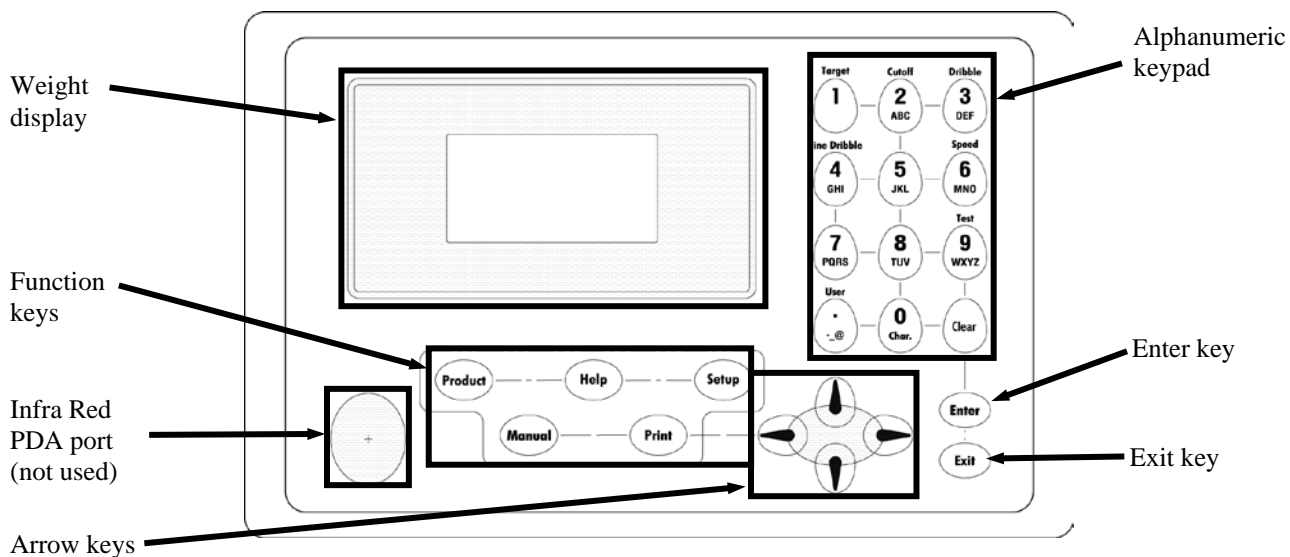
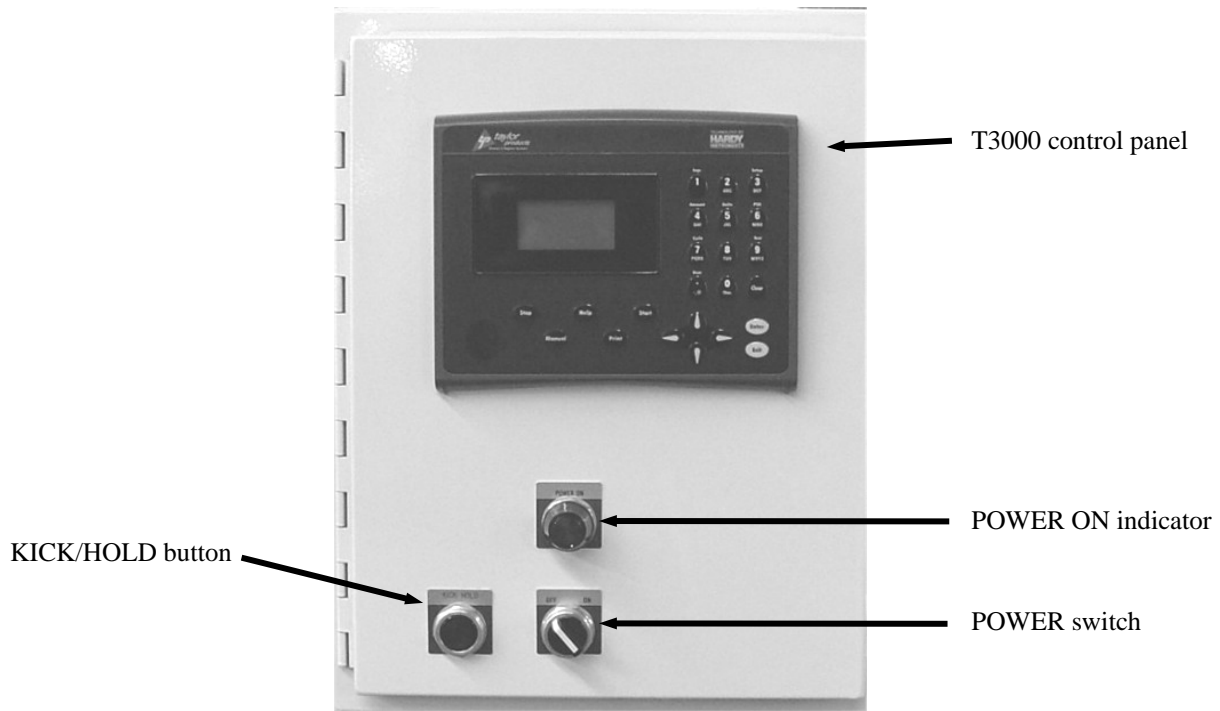

Figure 4-4. T3000 Faceplate Layout



**Figure 4-5.** T3000 Control Panel

## 4.4 Starting the Unit

Once the unit has been installed, and calibrated, it can now be started. The process for starting the Model IPV will vary based on the type of control set that is used.

## 4.5 Initial Setup

Model IPV units can be categorized based on their control type, as follows:

- T4000 control
  - Single set point
  - Dual set point
- T3000 control
  - Single set point
  - Dual set point

The setup procedure is different based on the type of Model IPV.

### 4.5.1 Setting Up a Single Set Point Model IPV With T4000 Controls

A single set point Model IPV will have a typical bagging cycle that will proceed as follows:

1. As soon as the STOP button is pulled out and the unit is turned on, the Model IPV will start filling the package with material.
2. Once the weight of the package reaches target weight (SP1) the Model IPV will engage the cutoff gate and stop the impeller.
3. Remove the package from the spout.
4. As soon as a new package has been placed on the spout and the bag clamp is activated (valve bag spouts), or the inflatable bladder has been inflated (open mouth bag spouts), the Model IPV will automatically begin filling the package. This cycle will repeat until the surge hopper is empty, or until the unit is turned off or stopped.

Before the Model IPV is put into operation, the initial setup procedure needs to be performed to ensure proper weighments. Follow the procedure outlined below to set up a single set point Model IPV for its first run. Before beginning this process, the operator should become familiar with the controls and functions of the Model IPV.

1. Turn on the power by turning the POWER switch to the ON position. Allow fifteen (15) minutes for the controls to warm up.

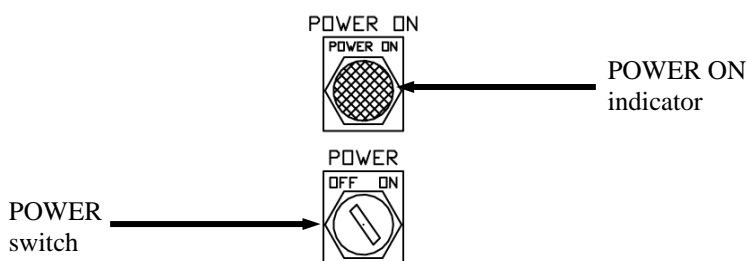

**Figure 4-6.** ON/OFF Switch

## Operation

2. Set the Target Weight. From the Standby screen, press the function key below SP1 on the display.

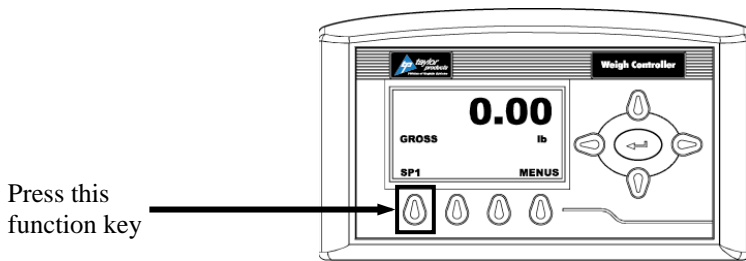

**Figure 4-7.** Initial Setup – Single Set Point

3. When the SP1 adjustment screen appears, use the up, down, left, and right arrows to adjust the SP1 setting.

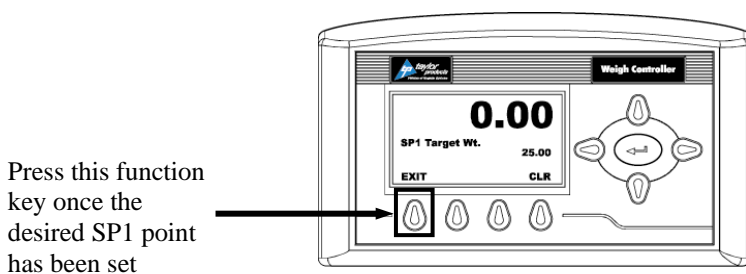

**Figure 4-8.** SP1 Adjustment Screen

4. When the adjustment to the SP1 setting is complete, press the function key below the EXIT on the display.

***Note:** Due to the weight of product in free fall, SP1 is typically set .3 to .7 lbs below the desired target weight. How much below the desired package weight will depend on the flow characteristics of the product.*

5. Place a bag on the spout.
6. Press the START button, or optional foot switch. The Model IPV will begin filling the package with material. After SP1 has been reached, and the impeller has stopped. **BEFORE** removing the package, check the weight display to see how close the actual package weight is to the target weight. If the actual package weight is more than or less than the target weight go back and adjust SP1 up or down by an amount equal to the difference between the target weight and actual weight.
7. Remove the package.
8. Install a new package on the spout and press the START button, or optional foot switch. Once again, the Model IPV will begin filling the package with material. After SP1 has been reached, and the impeller has stopped, check the weight display to make sure that actual weight matches the target weight. If the actual weight is on target, remove the package and install a new package on the spout and press the START button. There will be a short delay before the impeller begins filling the new package. It is important to make any SP1 correction before the package is removed. It may take several cycles before to get the machine properly set up for that specific product.

## 4.5.2 Setting Up a Dual Set Point Model IPV with T4000 Controls

A dual set point Model IPV will have a typical bagging cycle that will proceed as follows:

1. Turn the Model IPV on and pull the STOP button out.
2. Place a new bag on the spout and press the START button to apply the bag clamp and start filling the package with material at the bulk rate (Fast A).
3. When the package weight reaches SP1 the impeller will slow to the dribble rate (Slow A).
4. When the package weight reaches SP2, the impeller will reverse and then stop.
5. Remove the package by pulling the package off of the spout, or by using the optional foot switch to activate the kicker, or if using an automatic kicker, allow the kicker to remove the package.
6. As soon as the package has been removed, place a new package on the spout and press the START button to apply the bag clamp and begin filling the package. This cycle will repeat until the surge hopper is empty, or until the unit is turned off or stopped.

Before the Model IPV is put into operation, the initial setup procedure needs to be performed to ensure proper weightings. Follow the procedure outlined below to set up a dual set point Model IPV for its first run. Before beginning this process, the operator should become familiar with the controls and functions of the Model IPV.

1. Turn on the power by turning the POWER switch to the ON position. Allow fifteen (15) minutes for the controls to warm up.

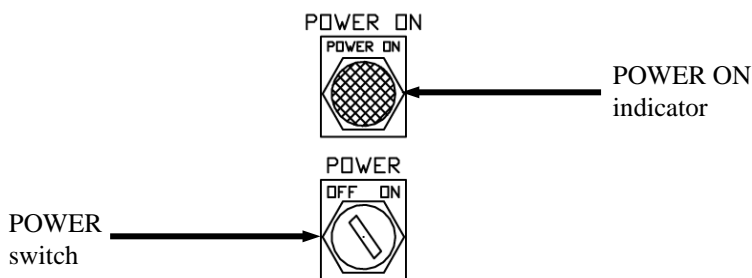

**Figure 4-9.** Model IPV ON/OFF Switch

2. Set the Dribble Weight. From the Standby screen, press the function key below SP1 on the display.

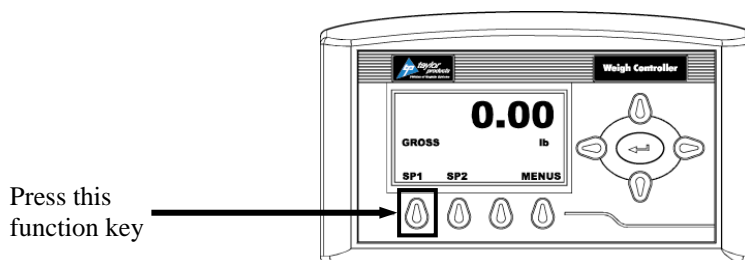

**Figure 4-10.** Setting the Dribble Weight (SP2)

3. When the SP1 adjustment screen appears, use the up, down, left, and right arrows to adjust the SP1 setting.

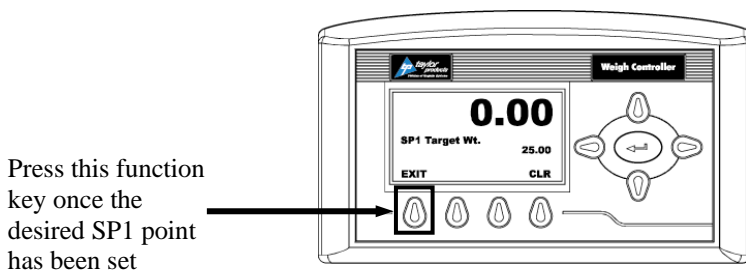

**Figure 4-11.** SP1 Adjustment Screen

4. When the adjustment to the SP1 setting is complete, press the function key below the EXIT on the display to return to the Standby screen.
5. Set the Target Weight. From the Standby screen, press the function key below SP2 on the display.

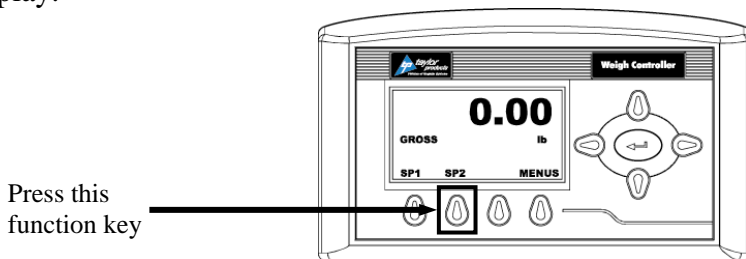

**Figure 4-12.** Setting the Target Weight (SP2)

6. When the SP2 adjustment screen appears, use the up, down, left, and right arrows to adjust the SP2 setting.

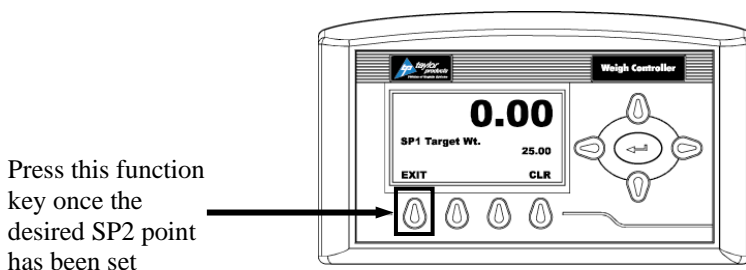

**Figure 4-13.** SP2 Adjustment Screen

7. When the adjustment to the SP2 setting is complete, press the function key below the EXIT on the display to return to the Standby screen.
8. Place a bag on the spout.
9. Press the START button, or optional foot switch. The Model IPV will inflate the neck seal and will begin filling the package with material. After SP2 has been reached, and the impeller has stopped. **BEFORE** removing the package, check the weight display to see how close the actual package weight is to the target weight. If the actual package weight is more than or less than the target weight go back and adjust SP2 up or down by an amount equal to the difference between the target weight and actual weight.
10. Remove the package.

11. Install a new package on the spout and press the START button, or optional foot switch, to inflate the neck seal. Once again, the Model IPV will begin filling the package with material. After SP2 has been reached, and the impeller has stopped, check the weight display to make sure that actual weight matches the target weight. If the actual weight is on target, remove the package and install a new package on the spout and press the START button to inflate the neck seal. There will be a short delay before the impeller begins filling the new package. It is important to make any SP1 correction before the package is removed. It may take several cycles before to get the machine properly set up for that specific product.

*Note: Also keep in mind that every time the impeller speed is changed, SP2 will most likely need to be adjusted. This adjustment alters the amount of product moving through the spout, thus changing the amount of material in free fall.*

### 4.4.3 Setting Up a T3000 to Fill

Model IPV units equipped with the T3000 can be programmed to fill as many as 25 different products. Use the steps below to select a specific product from the available list.

1. Check the T3000 to make sure the Filler is configured for the specific product that is being used.
2. Make sure the T3000 is in Standby Mode.
3. If the product shown on the display is the product that is going to be packaged, the setup is complete. If not, continue to step 4.
4. If the product shown on the Standby Menu is not the product being packaged, do the following:
  - a. Press the Product button once. A list of products that have been programmed into the control panel will appear. The currently selected product will be displayed.
  - b. The operator can change the product using the up or down arrow buttons to scroll through the available list of products. When the desired product is found, position the cursor next to it and press the Enter button. The menu for that product will appear, with the cursor adjacent to the Accept Settings line. Press Enter again to accept the settings, or use the up/down arrows to scroll through the available parameters for that product. To change a specific parameter, place the cursor next to that line and key in the new value for that parameter, followed by pressing the Enter button. When finished, scroll back to the Accept Settings line and press the Enter button to accept the changes.

#### 4.4.3.1 Using the T3000 to Set Up A Product From Scratch

To configure one of the 25 available product selections for a specific product, follow the steps below:

1. Press the Setup key once. The Configuration Menu will appear and will have the cursor on the ADJUST PRODUCT line. Press the Enter key.
2. The cursor will be positioned next to the currently selected product ID. Use the arrow keys to scroll down until the cursor is next to the first product number that has not been previously programmed.
3. Press the Enter key to select that product.
4. Position the cursor next to the line for the product name. Use the alphanumeric keypad to enter the name that has been selected for this product configuration. The default name can be used, but it is not recommended. Magnum Systems recommends using a name that provides some indication of what the product configuration is for. Press the Enter key to save the change.

## Operation

5. Scroll down to the Unit of Measure line. Use the left/right arrow keys to select the appropriate unit of measure (Lb, Oz, Kg, G). Press the Enter key to save the change.
6. Scroll down to the WAVERSAVER line. Use the alphanumeric keypad to enter the desired setting. Magnum Systems recommends setting the WAVERSAVER to 3.50 Hz. Press the Enter key to save the change.
7. Scroll down to the Averages line. Use the alphanumeric keypad to enter the desired setting. Press the Enter key to save the change.
8. Scroll down to the Jog line. Press the Enter key to access the Jog Menu.
9. Set Jog On Time to 0.000s, to disable the jog function. Press the Enter key to save the setting.
10. Press the Exit key.
11. Scroll down to the Fill Timer Line. Use the alphanumeric keypad to enter a new value, if desired. Press the Enter key to save the setting.
12. Scroll down to the Wait Timer line. Use the alphanumeric keypad to enter a new value, if desired. Press the Enter key to save the setting.
13. Scroll down to the Speeds line. Use the left/right arrow keys to select the Single speed setting. Press the Enter key to access the settings for that fill speed.
14. Use the left/right arrow keys to toggle between OFF and ON. When this option is ON, the controller will auto adjust the dribble point.
15. Leave the Mode setting at the factory preset setting.
16. Scroll down to the Fill Proof Menu and press the Enter key.
  - a. The Fast Switch and Slow Switch settings MUST be off for the machine to run.
  - b. The recommended setting for the Fast Switch Tmr and the Slow Switch Tmr is 5s.
17. Press the Exit key three times to return to the Standby Display.

## Chapter 5

# Preventive Maintenance

### 5.1 General Description

To minimize downtime, preventive maintenance should be made a priority. Proper preventive maintenance practices will also extend the life of the equipment. Developing a preventive maintenance schedule will ensure that critical maintenance procedures are not missed.

### 5.2 Daily Maintenance Procedures

At the start of each working day, the following maintenance tasks should be performed before starting the machine:

1. Thoroughly clean the machine.
2. Tighten any fasteners that may have become loose.
3. Drain any water that may have accumulated in the water separator in the air supply line.

#### 5.2.1 Cleaning

Keeping the Model IPV clean is an important part of the daily maintenance tasks. Remove any dust and/or dirt that has accumulated on a daily basis. Keeping the unit clean will keep debris from entering the control mechanisms, which could cause the performance of the Model IPV to suffer. Also, by taking the time to clean the Model IPV on a daily basis, the operator will be able to give the Model IPV a thorough inspection. Take the time to inspect all wiring, air supply lines and connections, and components for possible damage.

#### 5.2.2 Check All Fasteners

The operator should check all fasteners on the Model IPV on a daily basis. Loose fasteners can cause unwanted vibration and wear.

### 5.2.3 Drain Water From the FRL

It is very important to remove unwanted moisture from the incoming air to ensure proper operating of the pneumatic components. At the beginning of each day, the operator should empty the water from the FRL. Use the process below to drain the water.

1. Disconnect the air supply line.
2. Place a container under the drain valve.
3. There are two types of drain valves, follow the appropriate step below to open and close the drain valve:
  - a. If the water separator has a pin-type drain valve, press the pin upward and hold it in to drain the water. Release the pin once all water has drained.
  - b. If the water separator has a screw-type drain valve, turn the screw cap counter-clockwise to completely loosen the cap. After the water has completely drained, lightly push the cap upward to engage the threads and turn the cap clockwise until snug.
4. Discard the water from the container.
5. Reconnect the air supply line.



Figure 5-1. Filter/Regulator/Lubricator Assembly – Drain Valve

## 5.3 Monthly Maintenance

On a monthly basis, the Model IPV should be recalibrated. Refer to the 3.8 Calibration.

## Chapter 6

# Troubleshooting

### 6.1 General Description

When a problem occurs, proper troubleshooting techniques will allow maintenance personnel to quickly identify the problem.

### 6.2 The Troubleshooting Process

The actual troubleshooting process is just as important as the repair process. Use the following troubleshooting keys to assist with the troubleshooting process:

- Identify the trouble symptom
  - What is the problem?
  - What were the circumstances when the problem occurred?
  - Could weather be a factor?
  - Are there any other contributing factors?
- Sectionalize the problem
  - Look at the problem.
  - What area of the machine is the problem occurring in?
  - Has anything changed recently?
- Isolate the problem
  - Try simple things first.
  - Observe indication and trouble codes.
  - Check test points.
  - Avoid complicating the problem.

### 6.3 Trouble Symptoms

Use the following information to assist in troubleshooting.

#### 6.3.1 Scale is Not Accurate

If the load cell is providing inaccurate readings, check the following:

1. Check for proper calibration. Refer to 3.8 Calibration.
2. Check the hopper to make sure an adequate supply of material is available in the product hopper to ensure a consistent head pressure.
3. Check to make sure there is nothing restricting material flow from the hopper.
4. Make sure no foreign objects are coming in contact with the spout or weigh mast.

### 6.3.2 Scale Does Not Return to Zero

If the scale reading does not return to zero after the package has been removed from the spout, check the following items:

1. Check the weigh mast to make sure that it is level and is not binding. If the weigh mast is not level, check the flex leaves for damage/looseness. Replace/adjust flex leaves as necessary. Refer to 7.3.7 Flex Leaf Replacement.
2. Check the calibration. Refer to 3.8 Calibration.
3. Check for any outside interference, such as cords, hoses, etc., that would effect the movement of the weigh mast.

### 6.3.3 The Weighments are Always Too Light

If the weighments are consistently coming up too light, check the following:

1. Try lowering the dribble value (scale must have time to react, if material is coming in on the bulk rate too fast, the flow can cause a spike that will shut flow off too early).
2. Try lowering the bulk feed value.

### 6.3.4 Load Cell Fails Frequently



#### **CAUTION**

A sudden jerk or shock, such as being struck by a tool or hitting the spout, etc., can cause load cell damage. The load cell is NOT covered by warranty.

---

---

If the load cell on a Model IPV fails frequently, check the following items:

1. Check the operating conditions to make sure that the load cell is not jarred, jerked, or being loaded with a sudden excessive force.
2. Check the load cell to make sure that the product being weighed does not exceed the rating of the load cell.

### 6.3.5 Accuracy Problems While Doing a Wide Range of Weighments (i.e. 4 oz, 1 lb, and 5 lb)

1. Check the hopper to make sure that the product is not bridging.

### 6.3.6 Weighments are Erratic

If the weighments vary from too high to too low, check the following items.

1. Check the mechanical operation of the spout to make sure there is not anything coming into contact with the spout.
2. Check the hopper to make sure that the product is not bridging.
3. Check the condition of the flex leaves. Make sure they are not bent or broken.
4. Check the condition of the fill hose between the spout and the bulkhead. Make sure it is pliable and not dry rotted. If the fill hose is not pliable, or if dry rot is found, replace the hose. Refer to 7.3.6 Fill Hose Replacement.

5. Check the size of the package to make sure there is enough room for the product to fit into the bag without it having to be forced into the bag. A few inches are recommended for this. (To find out if this is happening lower the weight going into bag to see if it runs accurate).
6. Check to see if the bag is touching the kicker. The bag should not be touching the kicker.
7. For dual set point machines, check the dribble (SP1) and cutoff (SP2) set points. Once SP1 is achieved, the machine should run at the dribble rate for a minimum of two seconds for proper operation.
8. Check the operation of the adjustable pinch cylinder. Make sure it is working properly. It may be necessary to adjust the dribble, depending on product.
9. Check the load cell for proper operation. If the load cell is damaged or does not function properly, replace it.
10. Check the zero of the machine. Make sure it stays on zero and doesn't jump around. If the zero is unstable, a faulty load cell or zero pot may be the cause.

### **6.3.7 Machine Fails To Start After The START Switch Is Pressed**

If the Model IPV won't start when the START button is pressed, even though the machine is turned on, check the following items.

1. Check the start switch to see if the contacts are working properly.
2. Check the voltage to and from the start switch. The voltage should be 110 volts.
3. Check the MAC valve to see if it is getting voltage and the valve is functioning properly.
4. Check for the presence of voltage at the delay of start timer. If voltage is present, check to see if the valve changes states. If it does not change states, replace the MAC valve. Refer to 7.3.18 MAC Valve Replacement.
5. Check the MAC valve to see if it is getting air. If compressed air is not being supplied to the MAC valve, correct the air supply problem.
6. Check to see power is reaching the impeller motor. If power is not reaching the motor, check the power cable for opens or shorts. If power is reaching the motor, it may be necessary to replace the motor.

### **6.3.8 Fill speeds are too slow**

If the fill rate is slow, check the following items:

1. Check the drive belt tension for proper adjustment. Refer to 7.2.4 Drive Belt Tension Adjustment.
2. Check the adjustable pinch valve to make sure it is working properly.
3. Check the dribble (SP1) setting to make sure it isn't set too low. This would result in longer fill times.

## 6.4 System Alarms

During the filling process, conditions may occur that result in an alarm from the Model IPV. Depending on the type of controller used, the alarms will vary.

### 6.4.1 T4000 Alarms

During the filling process, conditions may occur that result in one of the following T4000 alarms:

- A/D Failure Error! – An internal electronics error has occurred. Retry the operation. If the failure error re-occurs, power the machine down, then restart the machine and try the operation again. If the operation still fails, contact Magnum Systems technical assistance.
- A/D Convert Error! – The input from the load cell is outside of the acceptable range. Check the load cell for damage. If a new load cell has been installed, check the rating of the load cell to make sure that the correct load cell has been installed.
- Motion Error! – The controller has detected that the vessel or product is in motion and the controller cannot finalize the weighment. Check the machine settings and retry.
- Trad Cal Error! – An error occurred during the calibration process. Try to calibrate the machine again. If the error occurs again, contact Magnum Systems technical assistance.
- C2 Cal Error! – This error should not occur, as Magnum Systems does not use C2<sup>®</sup> type load cells. If this error does occur, contact Magnum Systems technical assistance.
- Too Lo Error! – Verify that the load cell signal level is 0-15 mV. Verify that there is enough weight on the scale. Perform Span then go back and Zero.
- Too Hi Error! – Verify that the load cell signal level is 0-15mV. Verify that there is not too much weight on the scale. Perform Span then go back and Zero.
- No C2 Sensor! – Instrument did not detect a C2<sup>®</sup> Load Sensor. This error should appear if C2<sup>®</sup> Cal is selected, as Magnum Systems does not use C2<sup>®</sup> type load cells. If this error does occur, contact Magnum Systems technical assistance.
- CAL Failed! – There are too few counts between Zero and Span. Reset either of the values, so that the counts are more than 1,000 counts of each other.
- C2 Caps Unequal! – This error should not occur, as Magnum Systems does not use C2<sup>®</sup> type load cells. If this error does occur, contact Magnum Systems technical assistance.
- HI/LO Too Close! – The Zero and Span values are not more than 1,000 counts from each other or there is no change, or there is a negative change. Reset either of the values, so that the counts are more than 1,000 counts of each other.
- Function Error! – The operator has pressed a function button and the function did not work. Try the function again. If it does not work, cycle the power off and on. If it still doesn't work, contact Magnum Systems technical assistance.
- Not Allowed! – The value entered by the operator is outside of the range that is allowed. The operator should try another value that is within the acceptable range.
- Security Violation! – User signed in with a password that does not allow performance of a certain function or entry to certain menus. Security level of the user identified in the User ID, too low for the menu or function.
- Overrange – The final package weight has exceeded the set point target.
- Gross ADC Error – The controller has detected a load cell error. Check all load cell connections. Repair connections as necessary. Check the load cell for damage. Replace the load cell if necessary. Refer to 7.3.3 Load Cell Replacement.

## 6.4.2 T3000 Alarms

During the filling process, conditions may occur that result in an alarm from the T3000. There are 3 different categories of alarms:

- Fill alarms
- Jog alarms
- Filler discharge alarms

For a full description of these alarms, refer to Chapter 3: Operating Procedures/Filler, of the Magnum Systems Filler/Dispenser/IBC T3000 User Guide, that is included in Appendix E of this manual.

### 6.4.2.1 Fill Alarms

Fill alarms are used to indicate that current conditions will not allow the selected fill feature to function properly. These alarms are:

- Not OK to fill
- Lost OK to fill
- No fast feed
- Feed on
- No medium feed
- No slow feed
- Slow feed on
- Fill timeout
- Underfill/overflow

### 6.4.2.2 Jog Alarms

Jog alarms are used to indicate that current conditions will not allow the selected jog feature to function properly. These alarms are:

- Did not jog
- Jog stuck on
- Jog count

### 6.4.2.3 Filler Discharge Alarms

Filler discharge alarms are used to indicate that current conditions will not allow the selected fill feature to function properly. These alarms are:

- Not OK to discharge
- No discharge
- Discharge clogged
- Discharge on

This Page Intentionally Left Blank

# Chapter 7

## Repair and Adjustment

### 7.1 General Description

When troubleshooting procedures have indicated that a component needs to be repaired, replaced, or adjusted, following the procedures contained in this chapter will assist maintenance personnel to return the machine to operation in a timely manner.

### 7.2 System Adjustment Procedures

Depending on how the Model IPV is configured, there are several adjustments that may be required from time to time. They are:

- Air pressure adjustment
- Impeller shaft seal adjustment
- Kicker adjustment
- Drive belt tension adjustment

#### 7.2.1 Air Pressure Adjustment

The Model IPV requires compressed air to be at approximately 80-100 PSI (.55-.69 MPa) for proper operation. If air pressure is too high or too low, the air pressure regulator can be used to adjust the output air pressure.

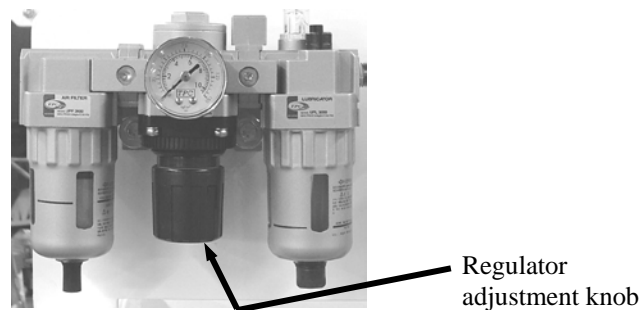

Figure 7-1. Air Pressure Adjustment

#### 7.2.2 Impeller Shaft Seal Adjustment

The impeller shaft seals should be adjusted any time they are replaced or if product begins leaking around the seals. When adjusting the tension on the seals, put just enough tension on the seals to prevent the product from leaking out. Too much tension will result in excess heat and will adversely affect the performance of the machine. Follow the procedure below to adjust the impeller shaft seals:

1. Loosen the jam nuts on the seal tension adjustment bolts.
2. Adjust seal tension using the seal tension adjustment bolts.
  - a. To increase the tension on the seal, turn the seal tension bolts clockwise
  - b. To decrease the tension on the seal, turn the seal tension bolts counter-clockwise.
3. Once the adjustment is complete, tighten the jam nuts to prevent the seal tension bolts from backing out.

## 7.2.3 Kicker Adjustment

The process for adjusting the kicker will differ between machines with T4000 controls, and those with T3000 controls.

### 7.2.3.1 T4000 Controls

The T1 pneumatic timer delay controller, located inside the electrical panel on the rear of the Model IPV, has an adjustment knob on the bottom that is used to regulate the amount of time that the kicker is extended. Turning the knob clockwise will decrease this amount of time, and turning the knob counter-clockwise will increase this amount of time.

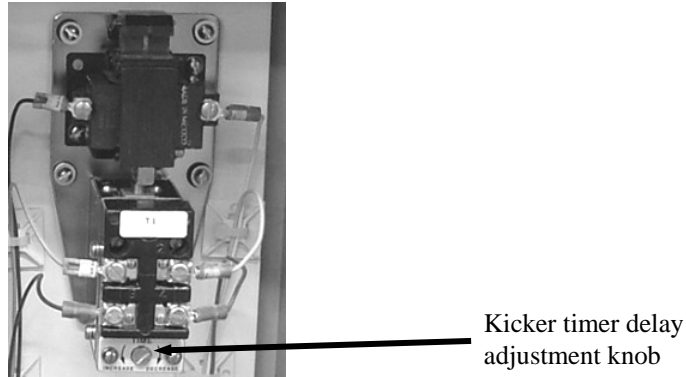

**Figure 7-2.** Kicker Timer Delay Adjustment Knob

### 7.2.3.2 T3000 Controls

When equipped with the T3000 control panel, the operator will adjust the kicker delay using the T3000 menu system. Refer to the T3000 Electronic Weigh Controller Quick Reference Guide from Magnum Systems for more information.

## 7.2.4 Drive Belt Tension Adjustment

The dual drive belts must have proper tension for the Model IPV to function correctly. If the belts are too tight, the result will be excessive loads on the bearings in the drive motor and the impeller shaft. If the belts are too loose, the belts will slip. Belt slippage can result in inconsistent product delivery and excessive wear on the belts.

The belts should be adjusted so that the belts can be deflected approximately  $\frac{1}{2}$ ".

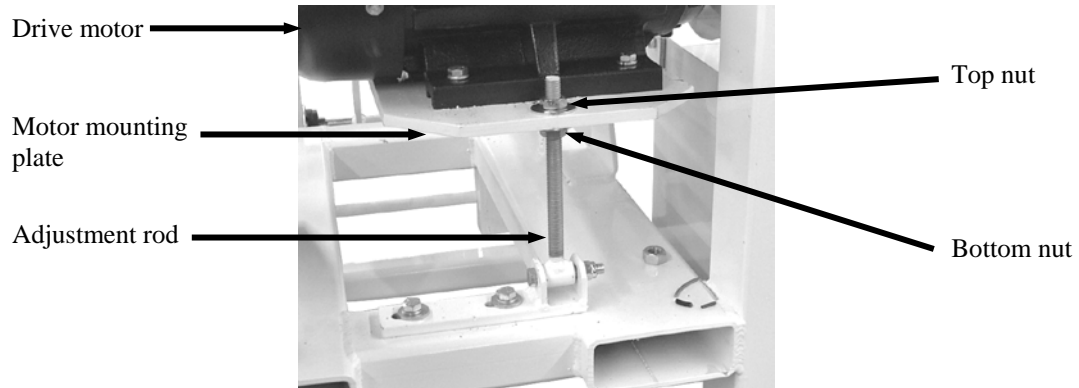

**Figure 7-3.** Belt Tension Adjustment Mechanism

1. Turn the Model IPV off.
2. Remove the drive belt cover.
3. Check the belt for proper tension (approximately  $\frac{1}{2}$ "). Push or pull on the belt to see how much it deflects.
  - a. If deflection is too little, loosen the bottom nut. Back the top nut off until the desired amount of deflection is achieved. Tighten the bottom nut against the motor mounting plate.
  - b. If deflection is too much, loosen the bottom nut. Tighten the top nut down against the motor mounting plate until the desired amount of deflection is achieved. Tighten the bottom nut against the motor mounting plate.
4. Turn the Model IPV on and test for proper operation.

## 7.3 Component Replacement Procedures

Over time, components on the Model IPV may become worn or damaged. If this occurs, follow the procedures in this section to repair or replace individual components.



### **WARNING**

*When replacing parts, it is critical that only parts approved by Magnum Systems are used.*

### 7.3.1 Spout Replacement

Due to the abrasiveness of some products, the spout will require periodic replacement. Use the procedures below to replace the spout.

#### 7.3.1.1 Valve Bag Spout Replacement

Use the procedures below for removing and installing the valve bag spout.

##### 7.3.1.1.1 Valve Bag Spout Removal

1. Turn the Model IPV off.
2. Disconnect the main electrical and pneumatic connections.
3. Remove the bag clamp cylinder. Refer to 7.3.9 Bag Clamp Cylinder Replacement.
4. Loosen the clamp on the spout end of the fill hose.
5. Pull the spout end of the fill hose so that it is free of the spout.
6. Remove the valve bag spout mounting bolts.
7. Remove the valve bag spout.

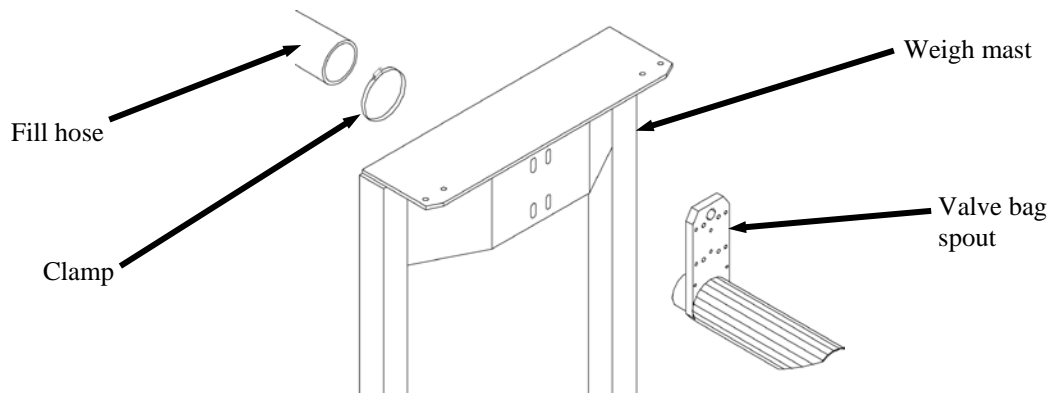

**Figure 7-4.** Spout Replacement

##### 7.3.1.1.2 Valve Bag Spout Installation

1. Position the new valve bag spout and install and tighten the mounting bolts.
2. Connect the spout end of the fill hose to the spout.
3. Position the fill hose clamp and tighten it to secure the hose to the spout.
4. Install the bag clamp cylinder. Refer to 7.3.9 Bag Clamp Cylinder Replacement.
5. Connect the main electrical and pneumatic connections.
6. Turn the Model IPV on and check for proper operation.

### 7.3.1.2 Open Mouth Bag Spout Replacement

If the open mouth bag spout becomes worn or damaged, use the procedures below to replace the spout.

#### 7.3.1.2.1 Open Mouth Bag Spout Removal

1. Turn the Model IPV off.
2. Disconnect the main electrical and pneumatic connections.
3. Loosen the fill hose to spout clamp.
4. Disconnect the fill hose from the spout.
5. Label and disconnect the two air supply lines from the spout.
6. Remove the two retaining nuts, washers, and bolts from the spout mount.
7. Support the spout with one hand while removing the retaining pin.
8. Slide the spout up and out of the mounting bracket.



Figure 7-5. Open Mouth Bag Spout Mounting Bracket

#### 7.3.1.2.2 Open Mouth Bag Spout Installation

1. Slide the spout into the mounting bracket from the top and align the holes.
2. Insert the retaining pin into the center hole.
3. Insert the two retaining bolts and install the washers and the nuts.
4. Use a wrench to hold the bolts, while using another wrench to tighten the nuts.
5. Slide the end of the fill hose over the fill tube on the spout.
6. Position and tighten the fill hose to spout clamp.
7. Connect the two air supply lines to the quick connect fittings on the spout.
8. Connect the main pneumatic connection at the FRL.
9. Check the air connections for leaks. Repair leaks as necessary.
10. Connect the main electrical connection.
11. Turn the Model IPV on and test for proper operation.

## **7.3.2 Inflatable Bladder Replacement (Open Mouth Bag Spout)**

Model IPV machines that are equipped to fill open mouth bags, utilize a large spout that has an inflatable bladder that is used to hold the bag on the spout and to keep prevent product from spilling out of the bag.

### **7.3.2.1 Inflatable Bladder Removal**

1. Turn the Model IPV off.
2. Disconnect the input power and compressed air supply line.
3. Label and disconnect the air supply line from the quick connect fitting on the spout.
4. Fold the flap up to expose the tabs and setscrews on the top compression ring.

**Figure 7-6.** Section View of Open Mouth Bag Spout and Inflatable Bladder

5. Using C-clamp style locking pliers, apply pressure to the tabs of the top compression ring.

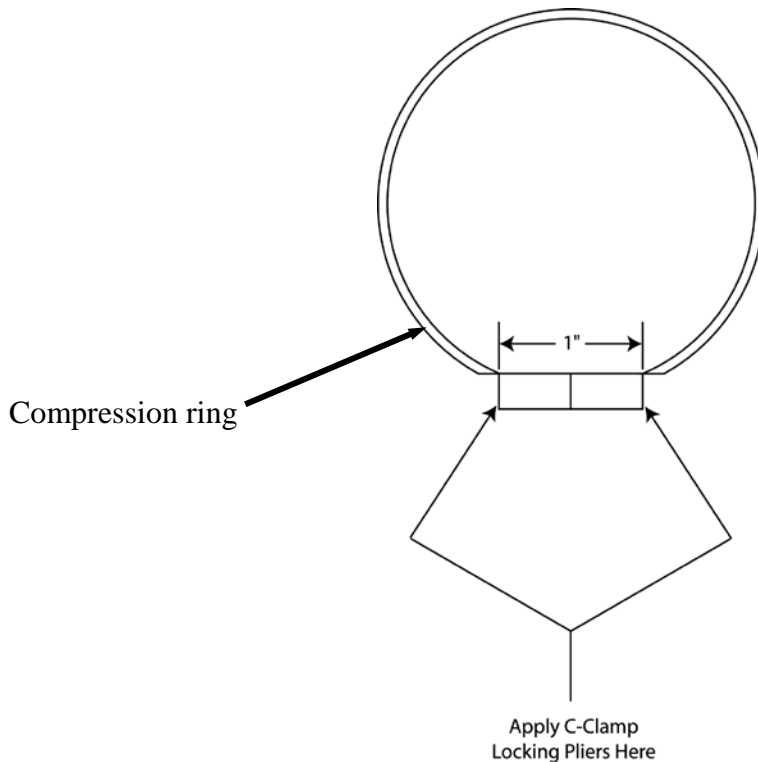

**Figure 7-7.** Inflatable Bladder Compression Ring

6. Remove the setscrews from the top compression ring.
7. Remove the C-clamp style locking pliers.
8. Slide the top compression ring off of the spout
9. Pull the bladder straight down to expose the second compression ring.
10. Using C-clamp style locking pliers, apply pressure to the tabs on the bottom compression ring.
11. Remove the setscrews from the bottom compression ring.
12. Remove the C-clamp style locking pliers.
13. Slide the bottom compression ring off of the spout.

**Note:** *The two compression rings are different sizes and cannot be interchanged.*

**Note:** *Make note of how the bladder is positioned. The new bladder will need to be positioned in the same manner as the one that is being removed.*

14. Remove the bladder.
15. Inspect the compression rings for damage or wear. If they are damaged or worn, discard them and install new ones with the new bladder.

### 7.3.2.2 Inflatable Bladder Installation

1. Turn the new bladder inside out.
2. Slide the new inflatable bladder on to the spout. Position it on the spout in the same position as the old bladder.

*Note: The two compression rings are different sizes and cannot be interchanged.*

3. Position the bottom compression ring.
4. Using C-clamp style locking pliers, apply pressure to the tabs on the bottom compression ring.
5. Install and tighten the setscrews for the bottom compression ring.
6. Remove the C-clamp style locking pliers.
7. Grasp the edge of the bladder at the bottom. Roll the edge outward and upward, creating a flap. This motion will begin the process of turning the bladder right side out.

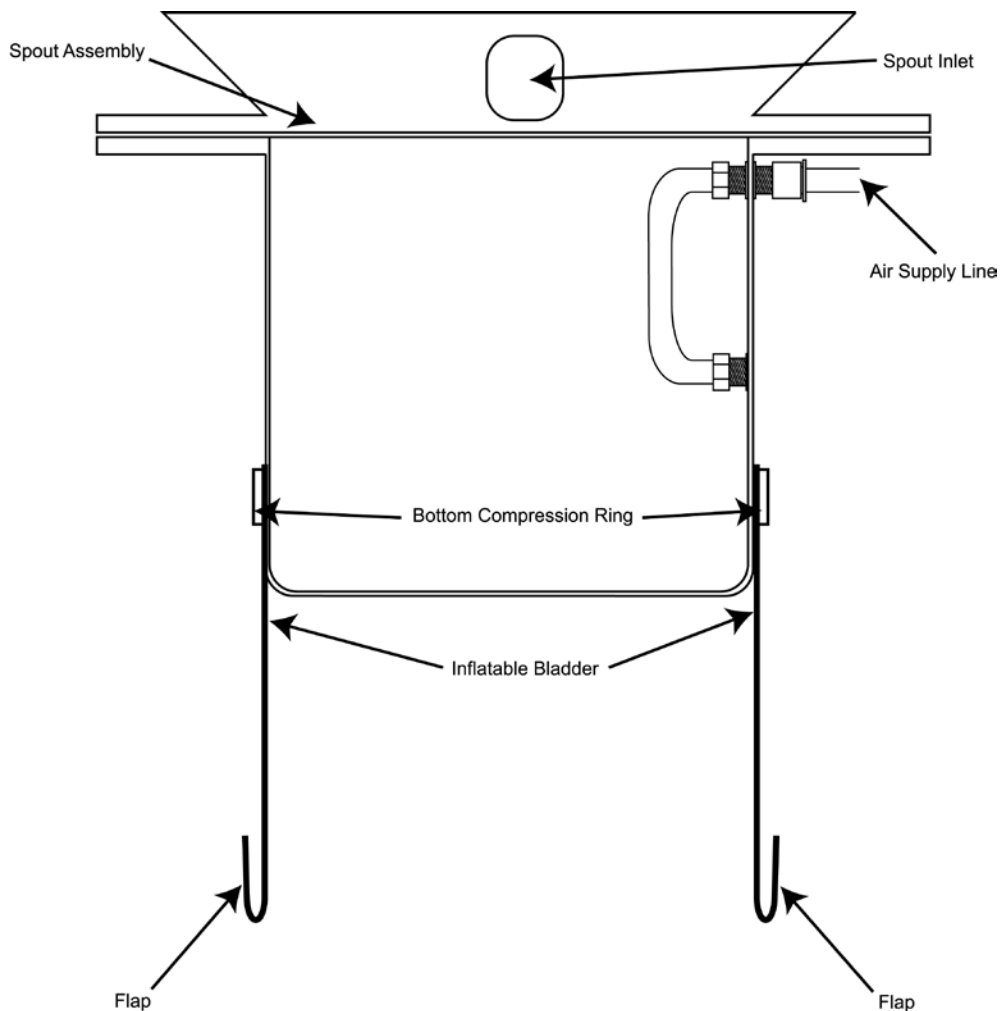

**Figure 7-8.** Creating the Flap

8. Using the flap, pull the bladder up to the top of the spout and roll the edge outward and downward, creating a new flap.

**Figure 7-9.** Pulling the Bladder Up, and Creating the Upper Flap

9. Slide the top compression ring into position.
10. Using C-clamp style locking pliers, apply pressure to the tabs on the top compression ring.
11. Install and tighten the setscrews for the top compression ring.
12. Remove the C-clamp style locking pliers.
13. Pull the flap down to cover the top compression ring.
14. Install the air supply line into the quick connect fitting.
15. Connect the main air supply line to the FRL.
16. Connect the Model IPV to its main power source.
17. Test the bladder for proper operation.

### 7.3.3 Load Cell Replacement

In the event that a load cell becomes damaged or fails to function, use the following steps to replace it.

**Important:** *Electronic load cells are not covered under the Magnum Systems warranty. Load cells are highly sensitive to shock or side load pressure. Never lift or move a machine by the weighing mechanism. Always use the shipping brackets when moving or shipping machines.*

#### 7.3.3.1 Load Cell Removal

1. Turn the Model IPV off.
2. Disconnect the main electrical and pneumatic connections.
3. Install the four shipping brackets.
4. Trace the cable from the load cell to the control box. Cut the wire ties that secure the load cell cable to the frame.
5. Open the control box.
6. Label the wire connections at the control module. Make a note of how the wires are connected.
7. Disconnect the wires from the control module.
8. Pull the cable free from the control box.
9. Remove the lower load cell mounting nut.
10. Remove the lower load cell mounting bolt.
11. Remove the upper load cell mounting nut.
12. Hold the load cell with one hand and remove the upper load cell mounting bolt.
13. Remove the load cell.

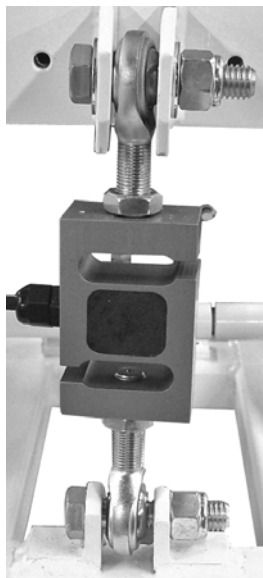

**Figure 7-10.** Load Cell Mounting

### 7.3.3.2 Load Cell Installation

1. Position the load cell with the top eye bolt in the upper bracket so that the eye is lined up with the bolt holes in the bracket.
2. Insert the upper load cell mounting bolt.
3. Loosely install the upper load cell mounting nut.
4. Position the load cell with the lower eye bolt in the lower bracket so that the eye is lined up with the bolt holes in the bracket.
5. Insert the lower load cell mounting bolt.
6. Loosely install the lower load cell mounting nut.
7. Tighten the upper and lower load cell mounting nuts. Do not overtighten, as this could lead to operational problems.
8. Route the cable to the control box.
9. Insert the cable into the control box, just as the cable was on the previous load cell.
10. Connect the wires from the cable to the control module, just as they were on the previous load cell.
11. Connect the main electrical and pneumatic connections.
12. Turn the Model IPV on and test for proper operation.

### 7.3.4 Drive Belt Replacement

Over time, the drive belts will wear or may become damaged. Use the following steps to replace the drive belts.

#### 7.3.4.1 Drive Belt Removal

1. Turn the Model IPV off.
2. Disconnect the main electrical and pneumatic connections.
3. Reduce the amount of tension on the belts until the belts can be slipped off of the pulley on the motor. Refer to 7.2.4 Drive Belt Tension Adjustment.
4. Remove the bolts that secure the drive belt cover to the machine.
5. Remove the drive belt cover.
6. Remove the drive belts.

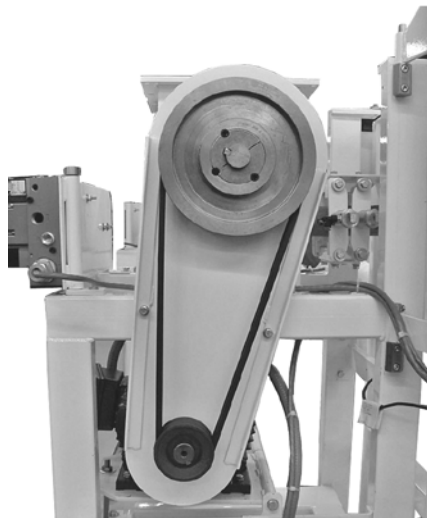

**Figure 7-11.** Drive Belts

### 7.3.4.2 Drive Belt Installation

1. Install the drive belts on the pulleys.
2. Adjust the tension on the drive belts. Refer to 7.2.4 Drive Belt Tension Adjustment.
3. Install the drive belt cover.
4. Install the drive belt cover mounting bolts.
5. Connect the main electrical and pneumatic connections.
6. Turn the Model IPV on and check for proper operation.

### 7.3.5 AC Motor Replacement

If the AC motor has failed and requires replacement, follow the steps below to replace it.

#### 7.3.5.1 AC Motor Removal

1. Turn the Model IPV off.
2. Disconnect the main electrical and pneumatic connections.
3. Reduce the amount of tension on the belts until the belts can be slipped off of the pulley on the motor. Refer to 7.2.4 Drive Belt Tension Adjustment.
4. Slip the two drive belts off of the pulley on the drive motor.
5. Open the cover on the electrical box on the side of the motor.
6. Label the wire connections and make note of how they are installed.
7. Loosen and remove the nuts from the motor mounting bolts.
8. Remove the mounting bolts.
9. Remove the motor.

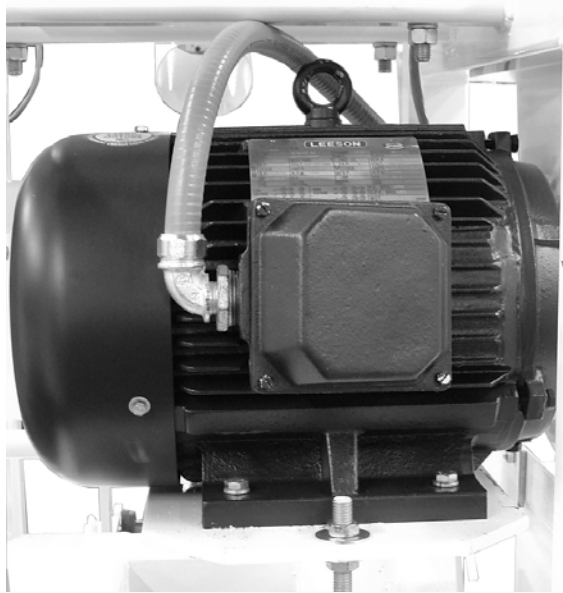

**Figure 7-12.** Drive Motor Mounting

### 7.3.5.2 AC Motor Installation

1. Position the motor on the mounting plate. Make sure that the drive shaft points toward the rear of the machine.
2. Line the mounting holes in the base of the motor up with the mounting holes in the mounting plate.
3. Install the four mounting bolts.
4. Install one washer and one nut on each mounting bolts. Do not tighten them all the way.
5. Slip the drive belts on to the pulley.
6. Check the alignment of the belts in the pulley. Make sure that the belts track straight through the pulley. If the motor is twisted slightly, it could cause excessive wear on the belts.
7. Tighten the mounting nuts.
8. Open the cover on the electrical box on the side of the motor.
9. Connect the wire connections.
10. Close the cover on the electrical box on the side of the motor.
11. Adjust the drive belts. Refer to 7.2.4 Drive Belt Tension Adjustment.
12. Connect the main electrical and pneumatic connections.
13. Turn the Model IPV on and test for proper operation.

### 7.3.6 Fill Hose Replacement

In the event that the rubber fill hose becomes damaged or wears out, follow the procedures below to remove and replace the fill hose.

#### 7.3.6.1 Fill Hose Removal

1. Disconnect the Model IPV from its main power source.
2. Disconnect the main air supply from the Model IPV at the Filter/Regulator/Lubricator (FRL).
3. Place a container under the fill hose to catch any product that may spill out.
4. Loosen the clamp on the impeller box end of the fill hose.
5. Loosen the clamp on the spout end of the fill hose.
6. Remove the fill hose from the impeller box outlet.
7. Remove the two clamps.
8. Remove the fill hose from the spout inlet and from the impeller box.

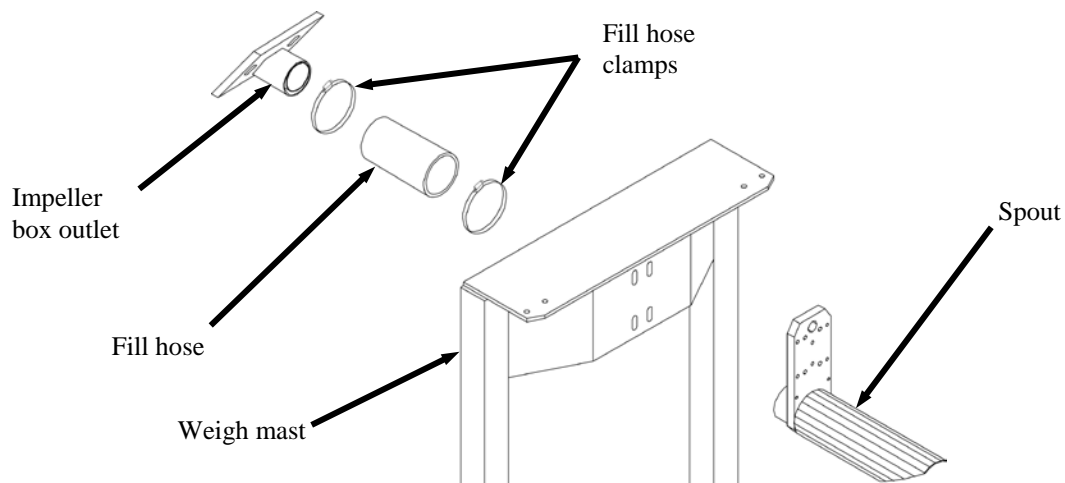

Figure 7-13. Fill Assembly, Exploded View

### 7.3.6.2 Fill Hose Installation

1. Slide one end of the new fill hose on to the inlet of the spout.
2. Slide the two clamps onto the hose.
3. Slide the other end of the new fill hose on to the outlet of the impeller box.
4. Position a clamp at each end of the fill hose and tighten the two clamps.
5. Connect the main air supply to the Model IPV.
6. Connect the Model IPV to its main power source.

### 7.3.7 Flex Leaf Replacement

In the event that a flex leaf needs to be replaced, use the procedures below.

#### 7.3.7.1 Flex Leaf Removal

1. Turn the Model IPV off.
2. Disconnect the main electrical and pneumatic connections.
3. Use a wrench to loosen and remove the flex leaf bolts.
4. Lift the flex leaf off of the Model IPV. Be careful not to misplace the shims, if used.

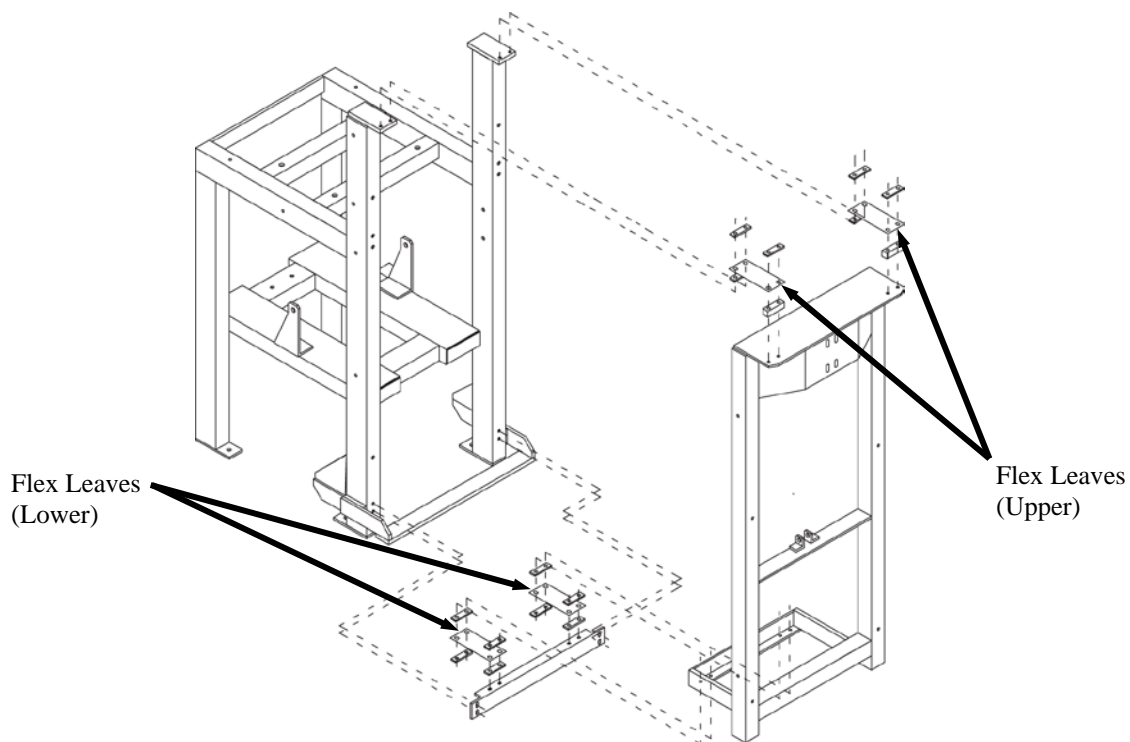

**Figure 7-14.** Flex Leaves – Exploded View

### 7.3.8.2 Flex Leaf Installation

1. Position the new flex leaf over the mounting holes.
2. Place the flex leaf bolts in their holes and begin threading them into the holes. Do not tighten them until all four bolts are threaded into their holes.
3. Before tightening the flex leaf bolts, make sure that the weigh mast is hanging level.
4. Use a wrench to tighten the flex leaf bolts.
5. Check the flex leaf to make sure it is level. Add shims if needed to level the flex leaf.
6. Connect the main electrical and pneumatic connections.
7. Turn the Model IPV on and test for proper operation.

## 7.3.8 Impeller Replacement

Over time, the impeller will wear and will eventually require replacement. The rate of wear will depend on the type of material that is being packaged and how abrasive that material is. Follow the procedures below to remove and install the impeller.

### 7.3.8.1 Impeller Removal

1. Turn the Model IPV off.
2. Disconnect the main electrical and pneumatic connections.
3. Place a container under the impeller box.
4. Empty the impeller box using the clean-out door on the bottom of the impeller box.
5. Close the clean-out door on the bottom of the impeller box.
6. Remove the catch container from under the impeller box.
7. Remove the setscrews that hold the two impeller halves together.
8. Remove the impeller halves.

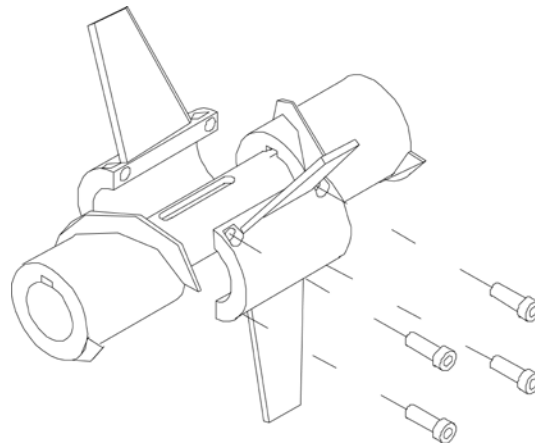

Figure 7-15. Impeller, Exploded View

### 7.3.8.2 Impeller Installation

1. Position the two impeller halves in their mounting location.
2. Insert and tighten the setscrews.
3. Connect the main electrical and pneumatic connections.
4. Turn the Model IPV on and test for proper operation.

## 7.3.9 Bag Clamp Cylinder Replacement

In the event that the bag clamp cylinder fails, use the procedures below to replace it.

### 7.3.9.1 Bag Clamp Cylinder Removal

1. Turn the Model IPV off.
2. Disconnect the main electrical and pneumatic connections.
3. Label and disconnect the air supply lines at the quick connect fittings on the bag clamp cylinder.
4. Remove the bag clamp pad. Refer to 7.3.10 Bag Clamp Pad Replacement.
5. Use a wrench to hold the bag clamp cylinder, while using a second wrench to remove the bag clamp cylinder retaining nut.
6. Remove the bag clamp cylinder by lifting it out of the mounting bracket.

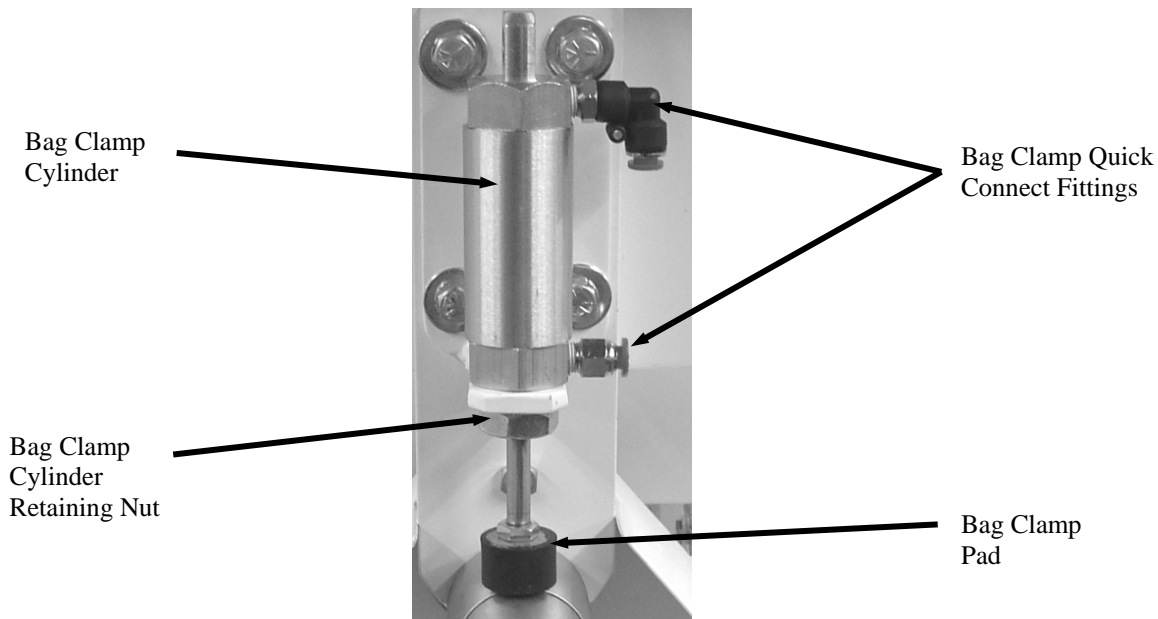

Figure 7-16. Bag Clamp Cylinder

### 7.3.9.2 Bag Clamp Cylinder Installation

1. Place the new bag clamp cylinder into the mounting bracket. Situate it so that when facing the Model IPV from the front, the quick connect fittings are on the right.
2. Install the bag clamp cylinder retaining nut. Use a wrench to hold the bag clamp cylinder while tightening the retaining nut with another wrench.
3. Install the bag clamp pad. Refer to 7.3.10 Bag Clamp Pad Replacement.
4. Connect the air supply lines to the quick connect fittings on the bag clamp cylinder.
5. Connect the main electrical and pneumatic connections for leaks.
6. Turn the Model IPV on and check for proper operation.

### 7.3.10 Bag Clamp Pad Replacement

During normal operation, the bag clamp pad will experience wear. Once the bag clamp pad has worn out, it must be replaced.

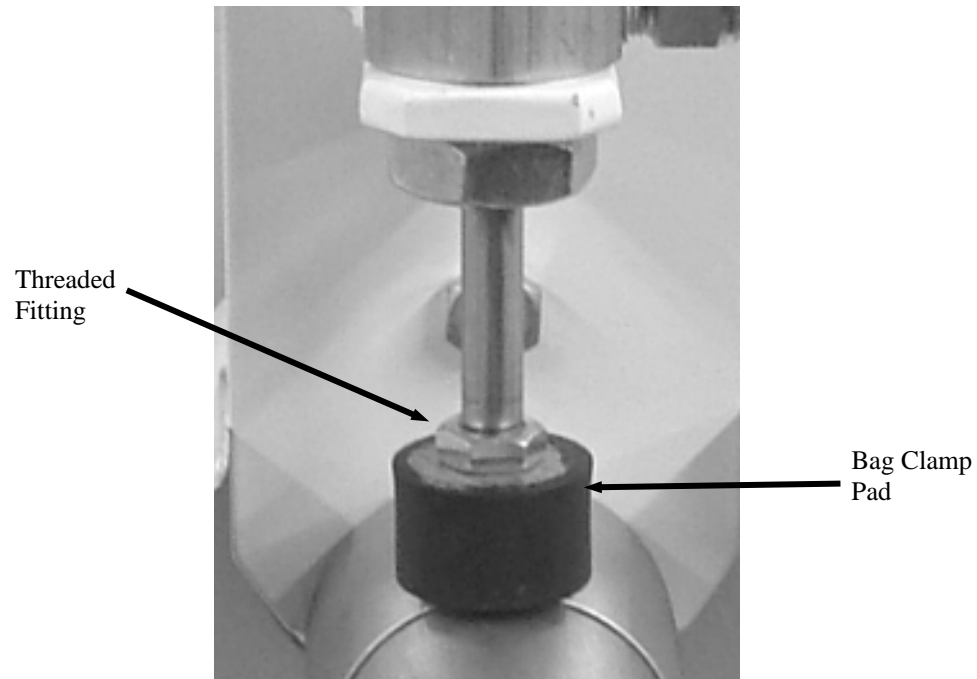

Figure 7-17. Bag Clamp Pad

#### 7.3.10.1 Bag Clamp Pad Removal

1. Turn the Model IPV off.
2. Disconnect the main electrical and pneumatic connections.
3. Use a wrench to hold the threaded fitting on the cylinder rod.
4. Unscrew the bag clamp pad from the cylinder rod.

#### 7.3.10.2 Bag Clamp Pad Installation

1. Screw the bag clamp pad on to the cylinder rod.
2. Use a wrench to hold the threaded fitting on the cylinder rod and tighten the bag clamp pad.
3. Connect the main electrical and pneumatic connections.
4. Turn the Model IPV on and test for proper operation.

## **7.3.11 Bag Clamp Actuator Switch Replacement**

If the bag clamp actuator switch fails to function, use the following steps to replace it.

### **7.3.11.1 Bag Clamp Actuator Switch Removal**

1. Turn the Model IPV off.
2. Disconnect the main electrical and pneumatic connections.
3. Trace the cable from the bag clamp to the control box. Remove any wire ties that are securing the cable to the frame.
4. Open the control box.
5. Label the wires from the cable to indicate how they are connected to the control module. Make a note of how the wires are connected.
6. Disconnect the wires from the control module.
7. Pull the cable free from the control box.
8. Remove the bag clamp actuator switch mounting bolts.
9. Remove the bag clamp actuator switch and pull the cable free from the frame.

### **7.3.11.2 Bag Clamp Actuator Switch Installation**

1. Position the bag clamp actuator switch.
2. Install and tighten the bag clamp actuator switch mounting bolts.
3. Route the cable to the control panel in the same manner as the cable on the switch that was previously removed.
4. Insert the cable into the control box through the same port used with the previous switch.
5. Connect the wires from the cable to the control box. Use the notes taken in step 5 of the removal procedure to make sure that the wires get connected correctly.
6. Close the control box.
7. Install new cable ties to secure the switch cable to the frame.
8. Connect the main electrical and pneumatic connections.
9. Turn the Model IPV on and test for proper operation.

### 7.3.12 Adjustable Pinch Cylinder Replacement

If the adjustable pinch cylinder develops a leak or fails to function, use the following steps to replace the cylinder assembly.

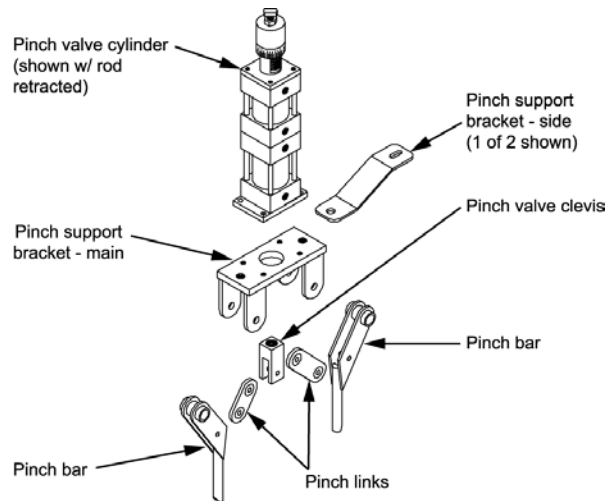

**Figure 7-18.** Adjustable Pinch Cylinder Mounting

#### 7.3.12.1 Adjustable Pinch Valve Cylinder Removal

1. Turn the Model IPV off.
2. Disconnect the main electrical and pneumatic connections.
3. Label and disconnect the air supply lines from the cylinder assembly.
4. Loosen and remove the bolts/nuts from that secure the pinch support bracket to frame brackets to the frame.
5. Lift the entire adjustable pinch valve assembly up and away from the Model IPV.
6. Loosen the jam nut that secures the clevis.
7. Back the cylinder rod out of the clevis.
8. Loosen and remove the bolts/nuts that secure the adjustable pinch valve cylinder to the adjustable pinch valve base.
9. Remove the adjustable pinch valve cylinder from the base.

#### 7.3.12.2 Adjustable Pinch Valve Cylinder Installation

1. Insert the rod end of the new cylinder through the hole in the base.
2. Install and tighten the bolts/nuts that secure the adjustable pinch valve cylinder to the adjustable pinch valve base.
3. Thread the cylinder rod into the clevis.
4. Tighten the jam nut.
5. Position the adjustable pinch valve assembly on the frame of the Model IPV so that the bolt holes in the mounting brackets are lined up with the bolt holes in the frame.
6. Install and tighten the bolts/nuts that secure the adjustable pinch valve to frame bracket to the Model IPV frame.
7. Connect the air supply lines to the air fittings on the cylinder.
8. Connect the main electrical and pneumatic connections.
9. Turn the Model IPV on and test for proper operation. Adjust the adjustable pinch valve as needed.

### **7.3.13 Adjustable Pinch Valve Bar Replacement**

If one of the pinch valve bars becomes worn or damaged, use these steps to replace it.

#### **7.3.13.1 Adjustable Pinch Valve Bar Removal**

1. Turn the Model IPV off.
2. Disconnect the main electrical and pneumatic connections.
3. Label and disconnect the air supply lines from the cylinder assembly.
4. Loosen and remove the bolts/nuts that secure the pinch support bracket to frame brackets to the frame.
5. Lift the entire adjustable pinch valve assembly up and away from the Model IPV.
6. Lay the adjustable pinch valve assembly on a workbench.
7. Loosen and remove the bolt/nut that secures the pinch valve bars to the pinch valve support bracket.
8. Loosen and remove the bolt/nut that secures the pinch valve bar to the pinch link.
9. Remove the pinch valve bar.

#### **7.3.13.2 Adjustable Pinch Valve Bar Installation**

1. Position the pinch valve bar.
2. Install and tighten the bolt/nut that secures the pinch valve bar to the pinch link.
3. Install and tighten the bolt/nut that secures the pinch valve bars to the pinch valve support bracket.
4. Position the adjustable pinch valve assembly on the frame of the Model IPV so that the bolt holes in the mounting brackets are lined up with the bolt holes in the frame
5. Install and tighten the bolts/nuts that secure the pinch support bracket to frame brackets to the frame.
6. Connect the air supply lines to the air fittings on the cylinder.
7. Connect the main electrical and pneumatic connections.
8. Turn the Model IPV on and test for proper operation. Adjust the adjustable pinch valve as needed.

### **7.3.14 Adjustable Pinch Valve Link Replacement**

If one of the pinch links becomes worn or damaged, use the following steps to replace it.

#### **7.3.14.1 Adjustable Pinch Valve Link Removal**

1. Turn the Model IPV off.
2. Disconnect the main electrical and pneumatic connections.
3. Label and disconnect the air supply lines from the cylinder assembly.
4. Loosen and remove the bolts/nuts that secure the pinch support bracket to frame brackets to the frame.
5. Lift the entire adjustable pinch valve assembly up and away from the Model IPV.
6. Lay the adjustable pinch valve assembly on a workbench.
7. Loosen and remove the bolt/nut that secures the pinch valve bars to the cylinder clevis.
8. Loosen and remove the bolt/nut that secures the pinch valve bar to the pinch link.
9. Remove the pinch valve bar.

### **7.3.14.2 Adjustable Pinch Valve Link Installation**

1. Position the pinch valve bar.
2. Install and tighten the bolt/nut that secures the pinch valve bar to the pinch link.
3. Install and tighten the bolt/nut that secures the pinch valve bars to the cylinder clevis.
4. Position the adjustable pinch valve assembly on the frame of the Model IPV so that the bolt holes in the mounting brackets are lined up with the bolt holes in the frame
5. Install and tighten the bolts/nuts that secure the pinch support bracket to frame brackets to the frame.
6. Connect the air supply lines to the air fittings on the cylinder.
7. Connect the main electrical and pneumatic connections.
8. Turn the Model IPV on and test for proper operation. Adjust the adjustable pinch valve as needed.

### **7.3.15 Air Supply Line Replacement**

In the event that an air supply line becomes damaged and requires replacement, follow the steps below to remove and replace the air supply line.

#### **7.3.15.1 Air Supply Line Removal**

1. Turn the Model IPV off.
2. Disconnect the main electrical and pneumatic connections.
3. Remove any clips and/or retainers that hold the damaged air supply line in place.
4. Disconnect the damaged air supply line from the components that it is connected to.
5. Remove the air supply line, making note of how the line is routed.

#### **7.3.15.2 Air Supply Line Installation**

1. Measure the air supply line that was just removed.
2. Cut a new length of air supply line, making sure that the ends of the line are cut square. Cut the new line to the same length of the one that was removed.
3. Route the new air supply line in the same manner as the one that was removed.
4. Insert each end of the new line into their fittings.
5. Reattach any clips and/or retainers to secure the air supply line.
6. Reconnect the main pneumatic connection and check for any leaks. If a leak is found, disconnect the main air supply line and then disconnect/reconnect the air connections, then reconnect the main air supply line. Repeat as necessary, until no leaks are present. It may be necessary to trim the end of an air supply line to resolve a leak. The ends must be cut square.
7. Connect the main electrical connection.
8. Turn the Model IPV on and test for proper operation.

## 7.3.16 Air Fitting Replacement

In the event that an air fitting becomes damaged and requires replacement, follow the steps below to remove and replace the air supply line.

### 7.3.16.1 Air Fitting Removal

1. Turn the Model IPV off
2. Disconnect the main electrical and pneumatic connections.
3. Disconnect the air supply line from the fitting being replaced by pressing and holding the collar in, and pulling out on the air supply line.
4. Using a wrench, unscrew the fitting.

### 7.3.16.2 Air Fitting Installation

1. Using Teflon® tape, wrap the threads of the new fitting, starting at the bottom of the thread working toward the hex head in the same direction as the threads.
2. Screw the new fitting into the threads and use a wrench to carefully tighten the fitting.

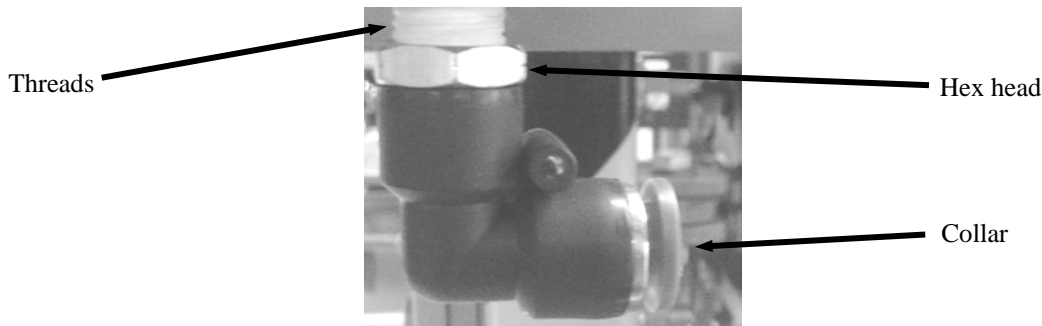
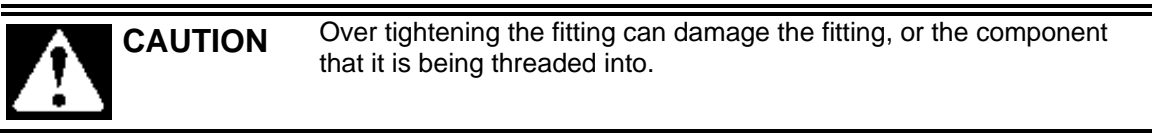

**Figure 7-19.** Air Supply Fitting

3. Reconnect the air supply line to the fitting.
4. Reconnect the main pneumatic connection and check for any leaks. If a leak is found, disconnect the main air supply line and then disconnect/reconnect the air connections, then reconnect the main air supply line. Repeat as necessary, until no leaks are present. It may be necessary to trim the end of an air supply line to resolve a leak. The ends must be cut square.
5. Connect the main electrical connection.
6. Turn the Model IPV on and test for proper operation.

### 7.3.17 Air Filter/Regulator/Lubricator (FRL) Replacement

In the event that the filter, the regulator, or the lubricator experiences a malfunction or becomes damaged, use the procedures below to replace the entire assembly.

#### 7.3.17.1 FRL Assembly Removal

1. Turn the Model IPV off.
2. Disconnect the main electrical and pneumatic connections.
3. Disconnect the output line from the lubricator.
4. Remove the FRL mounting bolts and remove the FRL.
5. Drain the oil from the lubricator and discard it in accordance to local laws.

#### 7.3.17.2 FRL Assembly Installation

1. Position the new FRL in the mounting location. Install and tighten the mounting bolts.
2. Connect the compressed air output line to the lubricator.
3. Fill the lubricator with the appropriate oil.
4. Connect the main pneumatic connection to the filter.
5. Check for air leaks.
6. Connect the main electrical connection
7. Turn the Model IPV on and check for proper operation.

### 7.3.18 MAC Valve Replacement

If a MAC valve fails, use the procedures below to remove and install a new one.

#### 7.3.18.1 MAC Control Valve Removal

1. Turn the Model IPV off.
2. Disconnect the main electrical and pneumatic connections.
3. Label and disconnect the air supply lines from the quick connect fittings on the air solenoid.
4. Remove the four solenoid mounting screws.
5. Remove the solenoid by pulling it straight out.

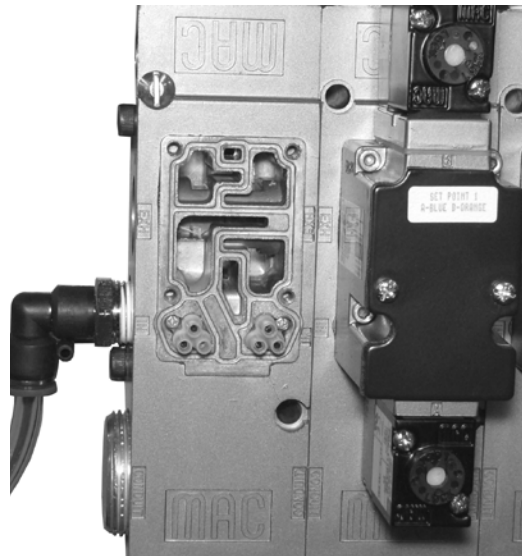

Figure 7-20. MAC Valve – Solenoid Removed

### **7.3.18.2 MAC Control Valve Installation**

1. Position the new solenoid and plug it into the base.
2. Insert and tighten the four mounting screws.
3. Connect the air supply lines to the appropriate fittings on the air solenoid.
4. Connect the main pneumatic connection.
5. Check the MAC valve for leaks. Repair any leaks as needed.
6. Connect the main electrical connection.
7. Turn the Model IPV on and check for proper operation.

### **7.3.19 Impeller Shaft Replacement**

In the event that the impeller shaft becomes damaged or worn, follow the procedures below to replace it.

#### **7.3.19.1 Impeller Shaft Removal**

1. Turn the Model IPV off.
2. Disconnect the main electrical and pneumatic connections.
3. Remove the impeller. Refer to 7.3.8 Impeller Replacement.
4. Loosen the setscrew on the drive pulley and slide it off of the shaft.
5. Remove the impeller shaft seals. Refer to 7.3.21 Impeller Shaft Seal Replacement.
6. Loosen the setscrews on the impeller shaft bearings.
7. Remove and secure the woodruff keys.
8. Slide the impeller shaft out of the impeller box.

#### **7.3.19.2 Impeller Shaft Installation**

1. Slide the impeller shaft in to the impeller box.
2. Place the shaft so that the keyways are on top and are situated just before the bearings.
3. Insert the woodruff keys into their respective keyways.
4. Rotate the bearings so that the keyway is on the top.
5. Slide impeller shaft into the bearings.
6. Once the impeller shaft is in final position, tighten the setscrews on the bearings.
7. Install the impeller shaft seals. Refer to 7.3.21 Impeller Shaft Seal Replacement.
8. Slide the drive pulley on the shaft. Once it is position, tighten the setscrew.
9. Install the impeller. Refer to 7.3.8 Impeller Replacement.
10. Connect the main electrical and pneumatic connections.
11. Turn the Model IPV on and test for proper operation.

## 7.3.20 Impeller Shaft Bearing Replacement

In the event that an impeller shaft bearing fails, or becomes damaged, follow the procedures below to replace it.

### 7.3.20.1 Impeller Shaft Bearing Removal

1. Turn the Model IPV off.
2. Disconnect the main electrical and pneumatic connections.
3. If the bearing that is being replaced is on the same side of the impeller box as the drive pulley, the drive pulley must be removed. To remove the pulley, loosen the setscrew and slide it off of the shaft.
4. Loosen the setscrew on the bearing.
5. Remove the four impeller shaft bearing retaining nuts.
6. Slide the bearing off of the mounting studs and off the impeller shaft.

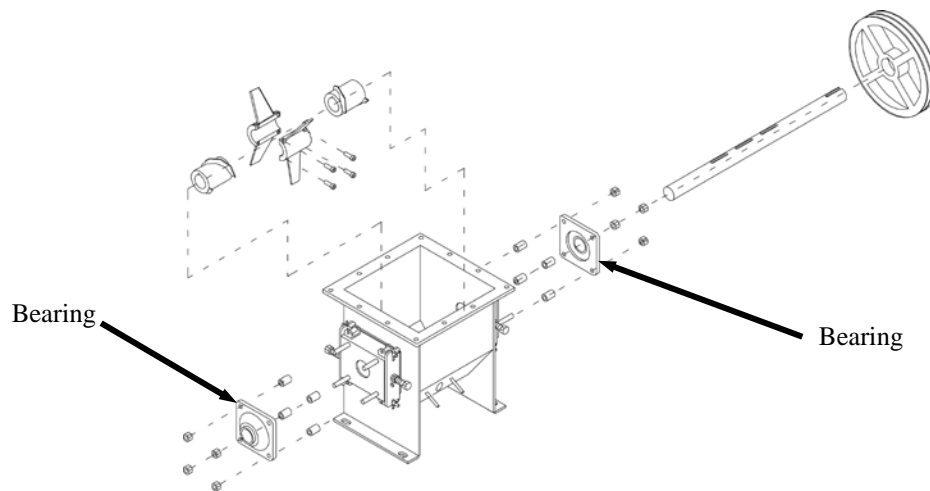

Figure 7-21. Impeller Shaft Bearings

### 7.3.20.2 Impeller Shaft Bearing Installation

1. Slide the new bearing on to the impeller shaft.
2. Align the slot in the bearing so that the bearing will be able to slide of the woodruff key and on to the mounting studs.
3. Install the four impeller shaft bearing retaining nuts and tighten them.
4. Tighten the setscrew.
5. If the bearing that is being replaced is on the same side of the impeller box as the drive pulley, the drive pulley must be installed. Slide the pulley on the shaft and tighten the setscrew.
6. Connect the main electrical and pneumatic connections.
7. Turn the Model IPV on and test for proper operation.

### 7.3.21 Impeller Shaft Seal Replacement

The impeller shaft has two seals on either side of the impeller box to prevent the product from leaking out of the impeller box around the impeller shaft. Each seal assembly consists of:

- Seal box
- Two seal halves (one for each side of the shaft)
- Two seal compression halves (one for each side of the shaft)
- Two seal covers (one for each side of the shaft)
- Four wing nuts (one for each end of each cover)
- Two seal tension adjustment bolts (one for each seal half)
- Two jam nuts (one for each seal tension adjustment bolt).

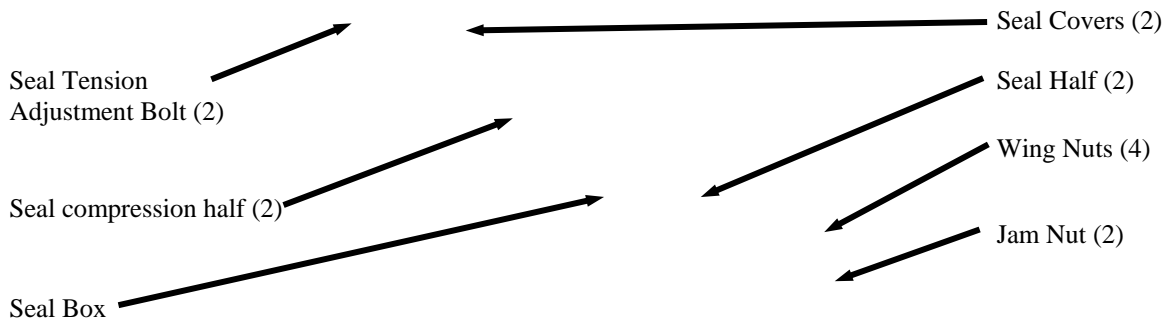

Figure 7-22. Impeller Shaft Seal, Exploded View

#### 7.3.21.1 Impeller Shaft Seal Removal

1. Turn the Model IPV off.
2. Disconnect the main electrical and pneumatic connections.
3. Loosen the jam nuts for the seal that is being replaced.
4. Back the seal tension adjustment bolts out almost all of the way.
5. Loosen the upper wing nut to allow the pivot bolt to be tilted up.
6. Remove the cover while being careful to not allow the compression half and seal half to fall out.
7. Remove the compression half and seal half.
8. Repeat steps 3 through 7 for the other half of the seal.

#### 7.3.21.2 Impeller Shaft Seal Installation

1. Insert the new seal half and compression half.
2. Position the cover so that the lower tab slot straddles the lower pivot bolt inside the wing nut.
3. Rotate the cover up into position, take care to align the IPV of the seal tension bolt with the bolt pocket on the compression half. It may be necessary to screw the bolt in some.
4. Lower the upper pivot bolt/wing nut into the upper tab slot and tighten the upper and lower wing nuts.
5. Repeat steps 1 through 4 for the other half of the seal.
6. Connect the main electrical and pneumatic connections.
7. Adjust the impeller shaft seal. Refer to 7.2.2 Impeller Shaft Seal Adjustment.
8. Turn the Model IPV on and test for proper operation.

### 7.3.22 Bleed Air Control Filter Replacement

The Porex wafer filter that is installed in the feed line between the bleed air control regulator/palm valve and the discharge spout.



#### CAUTION

Anytime that the wafer filter is removed, a new one should be installed. Failure install a new filter could result in damage to upstream controls.

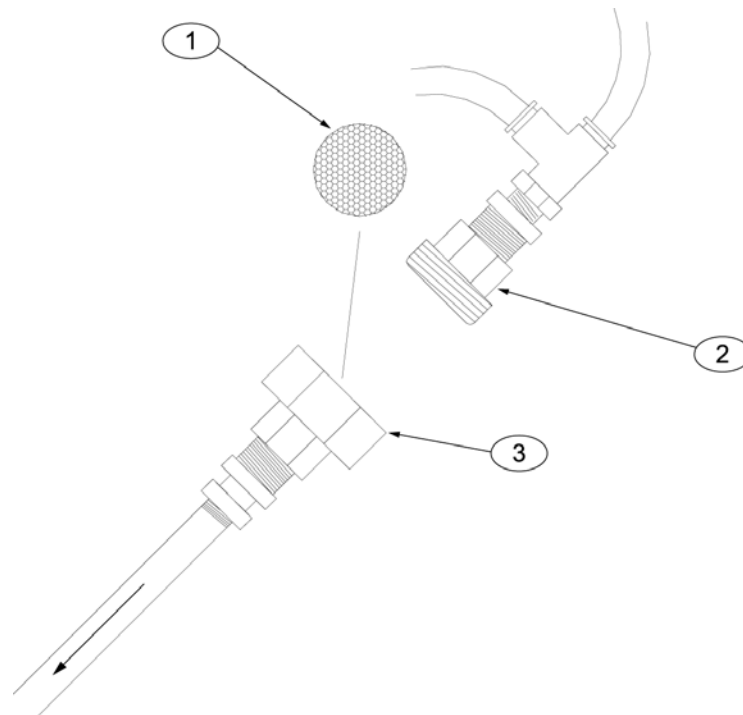

Item #	Description	Item #	Description
1	Wafer filter	3	Filter union - female side
2	Filter union - male side		

Figure 7-23. Bleed Air Control Wafer Filter

#### 7.3.22.1 Bleed Air Control Filter Removal

1. Turn the Model IPV off.
2. Disconnect the main electrical and pneumatic connections.
3. While using a wrench to hold the female side of the filter union, use a second wrench to loosen the male side of the filter union.
4. Open the union.
5. Remove the wafer filter.

#### 7.3.22.2 Bleed Air Control Filter Installation

1. Position the new wafer filter.
2. Thread the male side of the filter union into the female side of the filter union and tighten.
3. Connect the main electrical and pneumatic connections.
4. Turn the Model IPV on and test for proper operation.

Repair

This Page Intentionally Left Blank

## Glossary

<b>TERM</b>	<b>DEFINITION</b>
AC	Alternating Current
Bagging cycle	A series of functions that describe the packaging process, from beginning to end, for one package of product.
Base frame	Serves as the mounting point for all other components on the machine.
Bleed air control	Used to prevent and clear clogs in the discharge spout.
Bridging	A condition where an air pocket develops inside the hopper under the product and interrupts the flow of the product to the feed device.
Bulk rate	The fill speed used to package the largest portion of the product. It is a fast fill speed, as compared to the dribble rate.
Component	An item of hardware as commonly supplied complete by manufacturers.
Contact	Part of a switch that is made of two conducting components. The movement of the switch causes these two components to open and close. When closed, the two conducting components are touching, allowing the flow of electrons through the joined components.
Counter	A device that counts the occurrence of some event.
Cubic Feet/Minute (CFM)	A unit of measure that is used to describe the amount of compressed air that is used by a machine.
DC	Direct Current
De-energize	To deprive an electro-receptive device of its operating current.
Display	A device that gives information in visual form.
Dribble rate	The fill speed used to package the smallest portion of the product. It is a slow fill speed, as compared to the bulk rate.
Dual set point	Refers to a machine that has the capability of delivering the product at two different fill speeds.
ESD	Electrostatic Discharge
Failure	When a component or system does not operate as intended.
Fault	Violation of an operating system rule. Faults are minor or major; many major faults are not usually recoverable, even with fault routines.
Fill rate	A general term used to describe the speed at which the product is being fed.
Fill tube	A rubber tube that is used as the transmission path between the impeller box and the spout.
Filter/Regulator/ Lubricator (FRL)	A combination device that cleans contaminants and moisture from the incoming compressed air. This device also provides the operator with the ability to control how much air pressure is available at the outlet. The device also provides a reservoir that is filled with a special oil to help lubricate the internal components of the downstream pneumatic devices, such as MAC valves and pneumatic cylinders.
Fine dribble rate	On some units, a third feed rate may be used. This speed is slower than the dribble rate, and is used to top off the bag.
Flex leaf	Used to keep the weigh mast stable during the fill process.
Ground	A conducting connection, whether intentional or accidental, between an electrical circuit or equipment and the earth, or some other conducting body at a reference potential.
I/O	Input/Output
IN, in.	Inch, Inches
Infra Red (IR) port	A feature of the digital control set, it is used for transferring program/configuration information from a Personal Data Assistant (PDA) to the digital control panel. Rather than using a cable to transfer the data, this method used infrared light.
kg	kilogram
lb	Pounds
LCD	Liquid Crystal Display
LED	Light Emitting Diode. Typically will be used as status indicators for the PLC.

## Glossary

<b>TERM</b>	<b>DEFINITION</b>
Load cell	An electronic device that is used to monitor the weight of the product that is being packaged.
MAC valve	A pneumatic valve that is used for controlling various pneumatic cylinders. The valves apply air pressure to the cylinders causing them to either open or close.
mm	millimeter
Module	Assembly of components, which function as a unit and can be replaced as a unit.
OPC	OLE for Process Control
PLC	Programmable Logic Controller
Pounds per Square Inch (PSI)	Unit of measured used to describe air pressure.
POWER ON indicator	A lamp that will illuminate when power has been turned on.
Power supply	A device that converts available power to a form that a system can use — usually converts AC power to DC power.
Product	Refers to the material that is being packaged by the machine.
Reaction Time	The time used by equipment, operator, or both, that elapses between the moments an action is called for and when the desired result occurs.
Refrigerated Air Dryer	A device that is uses a refrigeration unit to remove moisture from a compressed air supply. This is done to reduce corrosion and contamination of the pneumatic equipment.
Relay	An electromagnetic device that is operated by a variation in the conditions of one electric circuit, to effect the operation of other devices in the same or another electric circuit.
RS-232	An EIA standard that specifies electrical, mechanical, and functional characteristics for serial binary communication circuits. A single-ended serial communication interface.
Set Point	A control setting that is used to define a transition point in the fill process. It can be a point when a change in fill rate occurs, or when the machine stops filling all together.
Set Point 1 (SP1)	The control setting that defines where the bulk feed rate is to stop.
Set Point 2 (SP2)	The control setting that defines where the dribble rate stops. Is typically slightly lower than target weight.
Shipping Bracket	A piece of metal that is used to secure the weighing apparatus to the base frame during shipping to prevent damage to the weighing apparatus.
Single Set Point	Refers to a machine that has the capability of delivering the product at a single fill speeds.
STOP button/indicator	Used by the operator to immediately stop the machine. Is a large red button that will illuminate when the stop button has been pressed. The machine will not start again until the button has pulled out.
Surge	A sudden rise of current or voltage.
Surge hopper	A reservoir where product is stored for packaging.
T3000	The optional electronic control panel. This device allows the operator to monitor and control the fill process.
T4000	The standard electronic control panel. This device allows the operator to monitor and control the fill process.
Target weight	The desired package weight.
VAC	Volt, alternating current
VDC	Volt, direct current
Water separator	A device that is installed in a compressed air supply line to remove excess moisture from the air supply. This is done to reduce corrosion and contamination of the pneumatic equipment.
Weighment	One charge or fill of a packaging machine.
Weight display	An electronic device that is used to display package weights and to set package parameters.
Zero knob	The control mechanism for adjusting machine to zero on machines with analog controls.

## Index

<p>AC Motor, ..... 1-8</p> <p>AC Motor Replacement, ..... 7-12</p> <p>Accuracy Problems While Doing a Wide Range of Weighments, ..... 6-2</p> <p>Adjustable Pinch Cylinder Replacement, ... 7-19</p> <p>Adjustable Pinch Valve, ..... 1-10</p> <p>Adjustable Pinch Valve Bar Replacement, ..... 7-20</p> <p>Adjustable Pinch Valve Link Replacement, ..... 7-20</p> <p>Air Filter/Regulator/Lubricator (FRL) Replacement, ..... 7-23</p> <p>Air Fitting Replacement, ..... 7-22</p> <p>Air Pressure Adjustment, ..... 7-1</p> <p>Air Supply Line Replacement, ..... 7-21</p> <p>Bag Clamp, ..... 1-9</p> <p>Bag Clamp Actuator Switch, ..... 1-10</p> <p>Bag Clamp Actuator Switch Replacement, ..... 7-18</p> <p>Bag Clamp Cylinder Replacement, ..... 7-16</p> <p>Bag Clamp Pad Replacement, ..... 7-17</p> <p>Bag Kicker, ..... 1-11</p> <p>Bag Settlers, ..... 1-12</p> <p>Base Frame, ..... 1-3</p> <p>Basic Fill Process, ..... 4-1</p> <p>Bleed Air Control Filter Replacement, ..... 7-27</p> <p>Bleed Air Control System, ..... 1-12</p> <p>Calibrating the Optional T3000 Control Panel, ..... 3-11</p> <p>Calibrating the T4000 Control Panel, ..... 3-9</p> <p>Calibration, ..... 3-9</p> <p>Check All Fasteners, ..... 5-1</p> <p>Cleaning, ..... 5-1</p> <p>Component Replacement Procedures, ..... 7-4</p> <p>Control Box With T3000 Control Panel, ... 1-15</p> <p>Control Box With T4000 Control Panel, ... 1-13</p> <p>Daily Maintenance Procedures, ..... 5-1</p> <p>Drain Water From the FRL, ..... 5-2</p> <p>Drive Belt Replacement, ..... 7-11</p> <p>Drive Belt Tension Adjustment, ..... 7-3</p> <p>Drive Belts, ..... 1-9</p> <p>Dry Cycle, ..... 3-8</p> <p>Dust Collection requirements, ..... 1-1</p> <p>Dust Conduit for Supply Hopper, ..... 3-2</p> <p>Dust Shroud, ..... 1-8</p>	<p>Electrical Connections, ..... 3-2</p> <p>Electrical Requirements, ..... 1-1</p> <p>Electro Static Discharge, ..... ii</p> <p>Electro-static Discharge (ESD) Prevention Procedures, ..... ii</p> <p>Field Service, ..... iii</p> <p>Fill Alarms, ..... 6-5</p> <p>Fill Hose Replacement, ..... 7-13</p> <p>Fill speeds are too slow, ..... 6-3</p> <p>Filler Discharge Alarms, ..... 6-5</p> <p>Filter/Regulator/Lubricator (FRL) Assembly, ..... 1-11</p> <p>Flex Leaf Replacement, ..... 7-14</p> <p>Flex Leaves, ..... 1-7</p> <p>General Fill Cycle Information, ..... 4-1</p> <p>Hopper, ..... 1-3</p> <p>Impeller Assembly, ..... 1-4</p> <p>Impeller Replacement, ..... 7-15</p> <p>Impeller Shaft Bearing Replacement, ..... 7-25</p> <p>Impeller Shaft Replacement, ..... 7-24</p> <p>Impeller Shaft Seal Adjustment, ..... 7-1</p> <p>Impeller Shaft Seal Replacement and Adjustment, ..... 7-26</p> <p>Important/Notable Information, ..... ii</p> <p>Inflatable Bladder Replacement (Open Mouth Bag Spout), ..... 7-6</p> <p>Initial Setup, ..... 4-5</p> <p>Jog Alarms, ..... 6-5</p> <p>Kicker Adjustment, ..... 7-2</p> <p>Load Cell, ..... 1-5</p> <p>Load Cell Fails Frequently, ..... 6-2</p> <p>Load Cell Replacement, ..... 7-10</p> <p>MAC Valve Replacement, ..... 7-23</p> <p>MAC Valves, ..... 1-9</p> <p>Machine Controls, ..... 1-13</p> <p>Machine Fails To Start After The START Switch Is Pressed, ..... 6-3</p> <p>Major Systems and Components, ..... 1-2</p> <p>Making Network Connections, ..... 3-3</p> <p>Manual Scope, ..... 1-1</p> <p>Mechanical Setup, ..... 3-1</p> <p>Monthly Maintenance, ..... 5-2</p> <p>Open Mouth Bag Spout, ..... 1-6</p> <p>Open Mouth Bag Spout Replacement, ..... 7-5</p> <p>Operation, ..... 4-1</p>
---	---

## Index

Operation Using Control Box With T3000	
Control Panel, .....	4-3
Operation Using Control Box With T4000	
Control Panel, .....	4-2
Operational Controls, .....	4-2
Packing Seal, .....	1-4
Personal Safety Instructions, .....	ii
Pneumatic Connections, .....	3-2
Pneumatic Requirements, .....	1-1
Preventive Maintenance, .....	5-1
Product Description, .....	1-1
Receiving Equipment, .....	2-1
Repair and Adjustment, .....	7-1
Safety Alert Symbols, .....	i
Scale Does Not Return to Zero, .....	6-2
Scale is Not Accurate, .....	6-1
Security Settings, .....	3-3
Setting Up a Dual Set Point Model IPV with	
T4000 Controls, .....	4-7
Setting Up a Single Set Point Model	
IPV with T4000 Controls, .....	4-5
Setting Up a T3000 to Fill, .....	4-9
Setup/Installation, .....	3-1
Spout, .....	1-5
Spout Replacement, .....	7-4
Starting the Unit, .....	4-5
Static Sensitive Symbols for Equipment	
Handling Instructions, .....	i
Supply Hopper, .....	3-1
System Adjustment Procedures, .....	7-1
System Alarms, .....	6-4
T3000 Alarms, .....	6-5
T3000 Security Settings, .....	3-7
T4000 Alarms, .....	6-4
T4000 Security Settings, .....	3-3
TRAD Calibration, .....	3-12
Trouble Symptoms, .....	6-1
Troubleshooting, .....	6-1
Troubleshooting Process, .....	6-1
Uncrating the Equipment, .....	2-1
Valve Bag Spout, .....	1-5
Valve Bag Spout Replacement, .....	7-4
Warranty Information, .....	iii
Weigh Mast, .....	1-7
Weighments are Always Too Light, .....	6-2
Weighments are Erratic, .....	6-2

## **Appendix A**

### **Safety Procedures, Cautions, Warnings, and Notices**

- General safety precautions must be observed during all phases of operation, service and repair of the Model IPV impeller packer. Failure to comply with these precautions or with specific warnings elsewhere in this manual violates safety standards of design, manufacture and intended use of the Model IPV.
- The manufacturer assumes no liability for customer's failure to comply with the following requirements:
- Qualified technicians and maintenance personnel should service the equipment described in this manual.
- Do not attempt internal service or adjustments unless another person, capable of rendering first aid and resuscitation, is available.
- Do not substitute parts or modify equipment. This practice could, in some cases, introduce the danger of additional hazards
- The Model IPV contains some electrostatic-sensitive components. Therefore, always ground yourself with a proper wrist strap before handling any modules or printed circuit boards so that static charges are removed from the person. Use static suppressive packaging to protect electronic assemblies removed from the Model IPV.
- Observe all procedural cautions and warnings located on the equipment and throughout this manual.
- Read and follow all instructions
- Follow all warnings and instructions marked on the units and listed in manuals.

This Page Intentionally Left Blank

## Appendix B Spare Parts

**Table B-1.** Model IPV Spare Parts List

	Part Description	Part Number
1	Fill Hose – 2.5" Gum Rubber Hose	50-1530
2	Bulk Head Hose – 2.5" Gum Rubber Hose	50-1530
3	Impeller <sup>1,2</sup>	IPV-210-00
4	Feed Screws to Impeller <sup>1,3</sup>	No Part #
5	Spout <sup>4</sup>	No Part #
6	Bag Clamp Cylinder	50-1159
7	Bag Clamp Pad	50-7440
8	Flex leaf	60-0165
9	Load cell	50-1546
10	Impeller shaft bearing assemblies	50-7023
11	Special trd pinch cylinder	50-7690
12	V-pinch clevis 303 – stainless steel	50-7691
13	V-pinch support bracket	60-3634
14	V-pinch support bracket	60-4056
15	V-pinch main frame	60-4054
16	5/16-inch – 18 X 2-inch bolt (special)	60-4055
17	V-pinch bars	60-4044
18	V-pinch link	60-4046
19	V-pinch shield	60-4053
20	Drive belt (2-required)	NAPA – A57
21	Impeller shaft seal	60-3551
22		
23		
24		
25		

<sup>1</sup> – The life of these parts depend on how abrasive the material is, and duty cycle (tons per day/hr, etc). If the material is highly abrasive, Magnum Systems recommends using a hard-faced impeller.

<sup>2</sup> – Refer to drawing IPV-210-00. Contact Magnum Systems (888-882-9567) with the machine serial number and the sales order number to get specific information.

<sup>3</sup> – Refer to drawings IPV-ELEC-212-00 and IPV-ELEC-211-00. Contact Magnum Systems (888-882-9567) with the machine serial number and the sales order number to get specific information.

<sup>4</sup> – Spouts vary per machine. Contact Magnum Systems (888-882-9567) with the machine serial number and the sales order number to get specific information.

***Note:** Part pricing is not provided in this manual. Contact Magnum Systems (888-882-9567) for pricing and availability.*

This Page Intentionally Left Blank

# Appendix C

## Mechanical Drawings

Table C-1. IPV Mechanical Drawing List

	<b>Drawing Title</b>	<b>Drawing Number</b>
1	Model IPV Isometric (Exploded View)	IPV-ISO-05.dwg
2	Adjustable Pinch Valve Operation	Adjustable Pinch Operation.dwg
3		
4		
5		
6		
7		
8		
9		
10		
11		
12		
13		
14		
15		
16		
17		
18		
19		
20		

This Page Intentionally Left Blank

# Appendix D Electrical Drawings

Table D-1. IPV Electrical Drawing List

	Drawing Title	Drawing Number
1		
2		
3		
4		
5		
6		
7		
8		
9		
10		
11		
12		
13		
14		
15		
16		
17		
18		
19		
20		

This Page Intentionally Left Blank

# Appendix E

## T3000 Control Panel User Guide

This Page Intentionally Left Blank

## **Appendix F Custom Features**

The documents included in Appendix F will provide information regarding any custom features that were ordered and included in the equipment purchase.

This Page Intentionally Left Blank

The equipment that accompanies this manual was not ordered with any custom features, thus no custom documentation is included.

This Page Intentionally Left Blank